

IQ-Link Handbook

Third Edition

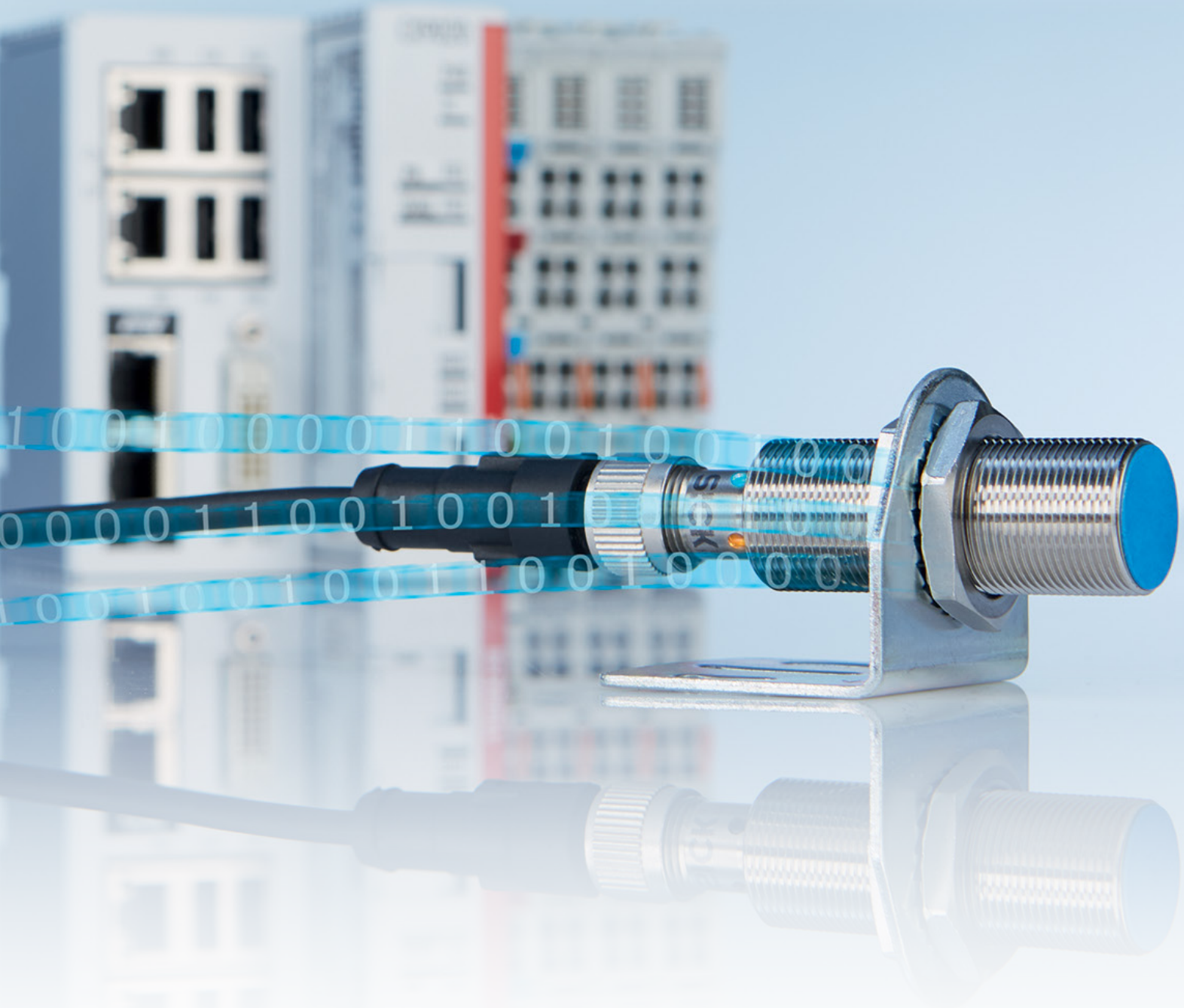

Table of Contents

Introduction	PAGE 4
Section 1: Introduction to IO-Link	PAGE 5
▶ Old School Sensor	PAGE 5
▶ Tiny Binary Sensor Drivers	PAGE 5
▶ IO-Link: An Open, Low Cost Sensor Interface	PAGE 5
▶ IO-Link Nodes	PAGE 5
▶ IO-Link System	PAGE 6
▶ IO-Link Interface Standardized as SDCI in IEC 61131-9	PAGE 6
▶ Physical Layer IO-Link Standardized Connectors	PAGE 6
▶ Physical Layer Electrical Specifications	PAGE 7
▶ IO-Link in the Automation Hierarchy	PAGE 7
▶ IO-Link: Enabling Intelligent Sensors	PAGE 7
▶ Industrial Sensor Ecosystem	PAGE 8
Section 2: IO-Link Environment	PAGE 9
▶ Data Link Layer	PAGE 9
▶ Data Types	PAGE 9
▶ Master-Device Communication	PAGE 9
▶ UART Data on the C/Q Line	PAGE 9
▶ Wake-Up Request	PAGE 9
▶ IO-Link Data Rate Selection	PAGE 10
▶ The IO-Link IODD	PAGE 10
Section 3: Designing an IO-Link Sensor	PAGE 11
▶ Sensor Design Considerations	PAGE 11
▶ IO-Link Smart Sensor Design Features	PAGE 11
▶ IO-Link Temperature Sensor: MAXREFDES164/MAXREFDES173	PAGE 11
▶ Description of Software	PAGE 13
▶ IO-Link Distance Sensor: MAXREFDES171/MAXREFDES174	PAGE 13
▶ Description of Software	PAGE 14
▶ IO-Link 16-Channel Digital Input Hub: MAXREFDES176	PAGE 14
▶ IO-Link Universal Analog IO: MAXREFDES177	PAGE 15
▶ IO-Link to Pmod-Compatible Adapter: MAXREFDES281, MAXREFDES284	PAGE 17
Section 4: Designing an IO-Link Actuator	PAGE 18
▶ IO-Link 8-Channel Solenoid Actuator: MAXREFDES278	PAGE 18
▶ PD-42-1-1243 IOLINK	PAGE 19
▶ TCM-1617-GRIP-REF	PAGE 19
Section 5: Designing an IO-Link Master	PAGE 20
▶ IO-Link Master Design Objectives	PAGE 20
▶ 8-Port IO-Link Master: MAXREFDES145	PAGE 20
▶ Description of Hardware	PAGE 20
▶ Description of Software	PAGE 21
▶ 4-Port IO-Link Master MAXREFDES165	PAGE 21
▶ Description of Hardware	PAGE 22
▶ Description of Software	PAGE 22
▶ IO-Link 2-Channel Master in Pmod-Compatible Form Factor: MAXREFDES277	PAGE 23
▶ IO-Link Master Test Reports	PAGE 23

Section 6: Improving System Performance	PAGE 24
▶ Heat Dissipation	PAGE 24
▶ Test A	PAGE 24
▶ Test B	PAGE 24
▶ Test C	PAGE 24
▶ Thermal Performance	PAGE 24
▶ Discrete Solution	PAGE 25
▶ Integrated Solution	PAGE 25
▶ Selecting a TVS Diode	PAGE 25
▶ IO-Link Protection	PAGE 25
▶ How 65 V (Abs Max) Helps with Protection (vs. 40 V)	PAGE 25
▶ Advantages of 65 V Abs Max for Protection	PAGE 25
▶ Summary	PAGE 26
▶ How Does IO-Link Signal Slew Rate Affect Emissions from the IO-Link Cable?	PAGE 26
▶ Electromagnetic Compatibility (EMC) Requirements	PAGE 27
▶ EMC Test Levels	PAGE 27
▶ Physical Layer: EMC Requirements Standardized	PAGE 27
▶ Immunity Testing	PAGE 27
<hr/>	
Section 7: IO-Link Solutions	PAGE 29
▶ Why Choose Maxim IO-Link Transceivers?	PAGE 29
▶ Product Selector Guide	PAGE 29
▶ 100 mA Tiny Binary Sensor Drivers: MAX14838/MAX14839	PAGE 29
▶ OTP Programmable Sensor Interface: MAX22520	PAGE 30
▶ Dual 250 mA IO-Link Transceiver: MAX14827A	PAGE 31
▶ Pin-Control, Low-Power, Dual-Channel IO-Link Device Transceiver: MAX14829	PAGE 32
▶ Surge-Protected Dual-Channel IO-Link Device Transceiver with DC-to-DC Converter: MAX22513	PAGE 32
▶ Surge Testing	PAGE 32
▶ IO-Link Transceiver with Integrated Protection: MAX22515	PAGE 33
▶ MAX22516 (Coming Spring 2023)	PAGE 34
▶ Dual-Channel IO-Link Master Transceiver: MAX14819A	PAGE 34
▶ Evaluating an IO-Link Device	PAGE 35
▶ Evaluating an IO-Link Master	PAGE 35
▶ Industrial IO-Link Reference Designs	PAGE 36
▶ ADI Reference Design Use Restrictions and Warnings	PAGE 36
<hr/>	
Appendix of Technical Resources	PAGE 37
▶ Software Stack Vendors	PAGE 37
▶ TMG Technologie und Engineering	PAGE 38
▶ TEConcept Tools	PAGE 44
▶ IQ ² Development Tools	PAGE 51
▶ Onsoon	PAGE 52
▶ IO-Link Glossary	PAGE 53
▶ IO-Link FAQs	PAGE 54
<hr/>	
Additional IO-Link Resources	PAGE 55
▶ IO-Link Webpages	PAGE 55
▶ IO-Link Application Notes and Articles	PAGE 55
▶ Videos	PAGE 55
▶ Trademarks	PAGE 55

Introduction

Today's fanless programmable logic controller (PLC) and IO-Link® gateway systems must dissipate large amounts of power depending on the I/O configuration (IO-Link, digital input/output, analog input/outputs). As these PLCs evolve into new Industry 4.0 smart factories, special attention must be considered to achieve smarter, faster, and lower power solutions. At the heart of this revolution is an exciting new technology called IO-Link, which enables flexible manufacturing to improve factory throughput and operational efficiency. This exciting new technology enables traditional sensors to become intelligent sensors.

At Analog Device, we provide a portfolio of advanced factory automation solutions that create pathways toward achieving Industry 4.0, enhanced by our [IO-Link technology portfolio](#). A recent addition to this portfolio is the [MAX22513](#), a tiny dual-channel IO-Link transceiver with integrated surge protection and a DC-to-DC converter, to reduce heat dissipation and increase the robustness of sensors on the factory floor.

To help our customers reduce their time to market, we have partnered with software stack vendors from the IO-Link consortium to develop a range of fully verified and tested reference designs, which are described in detail in this handbook.

IO-Link is a powerful technology that will play a pivotal role over time in factory process automation as well as other industries. It will not only save manufacturers billions every year but will expand new markets for more customization of products. If you are involved in factory process automation, watch IO-Link technology as it continues to unleash the true power of Industry 4.0 and changes the way we think of manufacturing.

Section 1: Introduction to IO-Link

Old School Sensor

Historically, a sensor included a sensing element and a way to get the sensing data to a controller. Data was often transferred in analog format (Figure 1) and was unidirectional (sensor to controller only). This added extra steps to the process (such as digital-to-analog and analog-to-digital conversion) that, in turn, added extra cost, larger footprints, and susceptibility to noise. Binary (or digital) sensors were used to simply indicate the status of a switch; for example, a thermostat to provide a high (24 V) or low (0 V) signal to indicate if the measured temperature is above or below a preset threshold. These “old school” sensors worked, but as technology advanced, sensor manufacturers integrated more functionality into sensors, eliminating some of these problems with these early sensors.

However, data was still limited to unidirectional communication from the sensor to the master, limiting error control and requiring a technician on the factory floor for updates or recalibration.

Manufacturers needed a better solution to meet the demands of Industry 4.0, smart sensors, and reconfigurable factory floors. The solution that emerged is IO-Link.

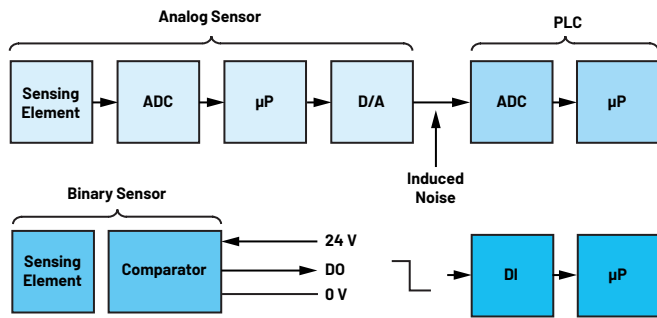

Figure 1. “Old School” sensors: analog and binary.

Tiny Binary Sensor Drivers

Binary sensors have only two states: on or off. Examples of binary sensors are pressure switches, temperature switches, through-beam photoelectric sensors, proximity sensors, and pushbuttons. Binary sensor output drivers, such as the MAX14838/MAX14839 (Figure 2), are 24 V/100 mA drivers optimized for use in industrial sensors. These devices integrate the high voltage (24 V) circuitry commonly found in industrial sensors, such as a configurable or pin-selectable PNP/NPN/push-pull driver and an integrated linear regulator that meets common sensor power requirements. The output driver interfaces between the sensor or sensor microcontroller unit (MCU) and the digital input (DI) module of the PLC.

To provide flexibility in supporting a broad range of physical sensor types, logic inputs allow the output driver to be configured for high-side (PNP), low-side (NPN), or push-pull operation. An additional input allows the user to select between normally open and normally closed logic. The MAX14838/MAX14839 are highly integrated products, making them ideal for robust sensor solutions in a tiny footprint due to integrated reverse-polarity protection, an on-board LDO regulator, and LED drivers.

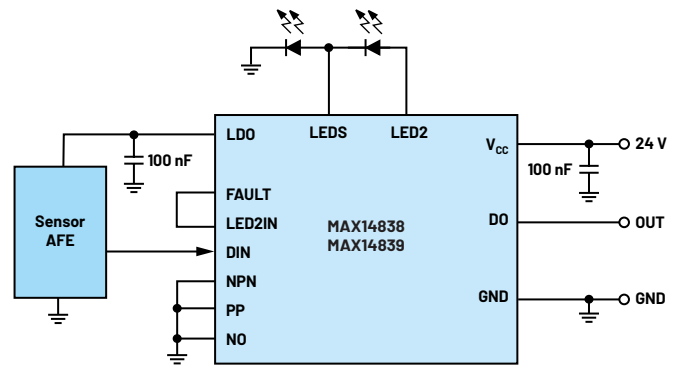

Figure 2. A 24 V pin-configurable industrial sensor output driver.

IO-Link: An Open, Low Cost Sensor Interface

IO-Link is a standardized technology (IEC 61131-9) regulating how sensors and actuators in industrial systems interact with a controller. The IO-Link Company Community (io-link.com) was formed in 2008 by a group of 41 sensor and actuator manufacturers who started the IO-Link consortium with the goal to standardize the hardware (PHY layer) interface and the communication (data) protocol for IO-Link products. Currently, there are over 100 companies in the consortium including semiconductor vendors and software vendors. Maxim, now part of ADI, has been a member of the IO-Link consortium since 2009.

IO-Link is a point-to-point communication link with standardized connectors, cables, and protocols. The IO-Link system is designed to work within the industry-standard 3-wire sensor and actuator infrastructure and is comprised of IO-Link master and IO-Link device products (Figure 3).

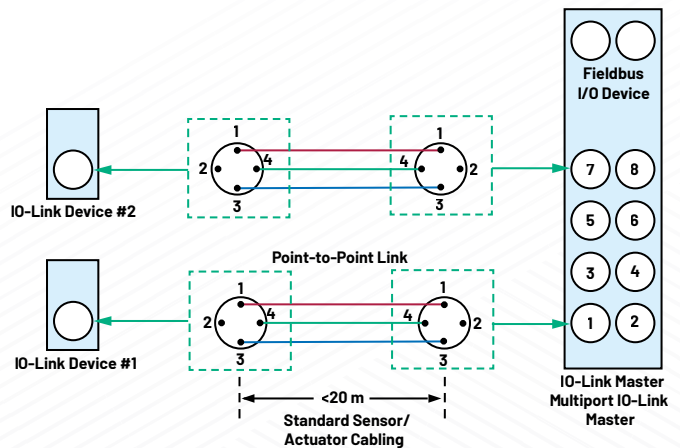

Figure 3. IO-Link master/device interface.

IO-Link Nodes

The number of installed IO-Link nodes continues to rapidly grow as sensor companies move from older analog sensors to smart IO-Link-based sensors, enabling the promise of reconfigurable manufacturing as outlined by Industry 4.0 (Figure 4).

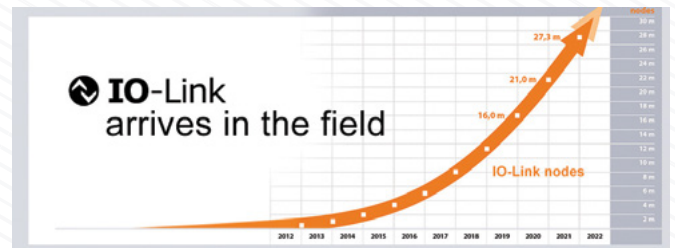

Figure 4. Growth in the number of IO-Link nodes installed.

IO-Link System

The point-to-point connection between the IO-Link master (multiport controller or gateway) and the IO-Link device (sensor or actuator) uses standard connectors (usually M12) and a 3- or 4-wire cable up to 20 meters in length. The master can have multiple ports (commonly four or eight). Each port of the master connects to a unique IO-Link device, which can operate in either SIO mode or bidirectional communication mode. IO-Link is designed to work with existing industrial architectures such as fieldbus or Industrial Ethernet and connects to existing PLCs or human-machine interfaces (HMIs), enabling rapid adoption of this technology (Figure 5).

For full details of IO-Link, refer to the IO-Link Interface and System Specification Version 1.1.3 dated June 2019 at io-link.com.

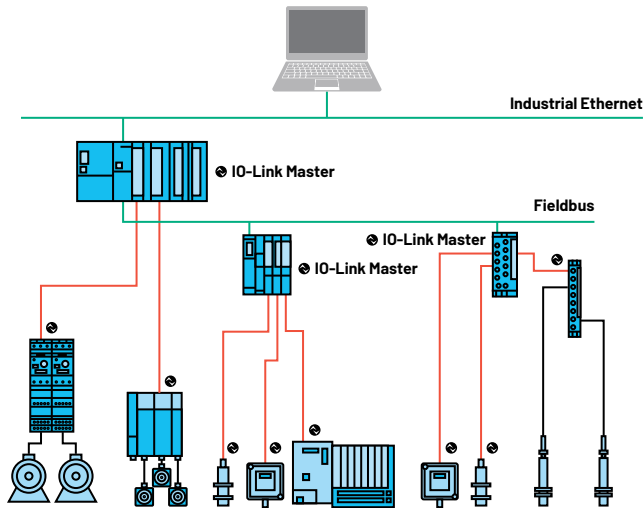

Figure 5. IO-Link compatibility with existing industry protocols.

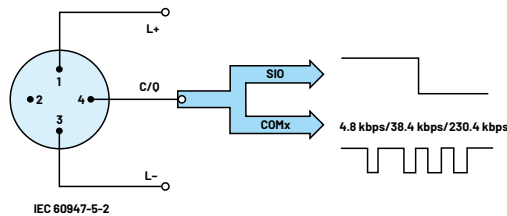

Figure 6. IO-Link pin definitions.

IO-Link Interface Standardized as SDCI in IEC 61131-9

IO-Link is a standard for single-drop communication interface (SDCI), which was standardized as IEC 61131-9, while also providing backward-compatibility with binary sensors IEC 60974-5-2 (Figure 6 and Table 1). IO-Link sensors have the best features of binary sensors while adding bidirectional data capability. IO-Link masters can interface with both binary and IO-Link sensors, allowing IO-Link to be easily added to an existing system. The IO-Link standard states that communications must be within 20 meters with unshielded cables using standard connectors common to industrial systems. M8 and M12 connectors are the most predominant. Communication is point-to-point and requires a 3-wire interface (L+, C/Q, and L-). Communication between an IO-Link master and device is half-duplex with three transmission rates: COM1 4800 baud, COM2 38.4 kbaud, and COM3 230.4 kbaud.

The supply range in an IO-Link system is 20 V to 30 V for the master, and 18 V to 30 V for the device (sensor or actuator). The IO-Link device must function within 300 ms after L+ exceeds the 18 V threshold.

The two communication modes are standard I/O (SIO) and SDCI. SIO mode ensures backward compatibility with existing sensors in the field, using 0 V or 24 V to signal OFF or ON to the IO-Link master. In IO-Link mode, communication is bidirectional at one of three data rates. The IO-Link device only supports one data rate while the IO-Link master must support all three data rates. Communication is with 24 V pulses using a nonreturn-to-zero (NRZ) coding scheme on the C/Q line where a logic 0 is 24 V between CQ and L- and a logic 1 is 0 V between CQ and L-. In IO-Link mode, pin 2 can be in DI mode as a digital input, or DO mode as a digital output, or not connected (NC).

Table 1. IO-Link Pin Definitions

Pin	Signal	Designation	Standard
1	L+	24 V	IEC 61131-2
2	I/O	Not connected, DI, or DO	IEC 61131-2
3	L-	0 V	IEC 61131-2
4	Q	Switching signal (SIO)	IEC 61131-2
	C	Coded switching (COM1, COM2, COM3)	IEC 61131-9

Physical Layer IO-Link Standardized Connectors

Standardized connectors and cables are used as defined by IEC 61131-9. Port Class A connectors have 4-wire connections (maximum) to support the 3-wire connection system (L+, L-, C/Q) with a fourth wire that can be used as an additional signal line (DI or DO). Port Class B connectors have 5-wire connections for devices that require extra power from an independent 24 V supply (Figure 7 and Table 2).

Table 2. Alternative IO-Link Pin Definitions

Pin	Signal	Designation	Remark
1	L+	Power supply (+)	See Table 7*
2	I/O P24	NC/DI/DO (port class A) P24 (port class B)	Option 1: NC (not connected) Option 2: DI Option 3: DI, then configured DO Option 4: Extra power supply for power devices (port class B)
3	L-	Power supply (-)	See Table 7*
4	C/Q	SIO/SDCI	Standard I/O mode or SDCI
5	NC N24	NC (port class A) N24 (port class B)	Option 1: Shall not be connected on the master side (port class A) Option 2: Reference to the extra power supply (port class B)

* In the IO-Link Interface and System Specification Version 1.1.3, June 2019

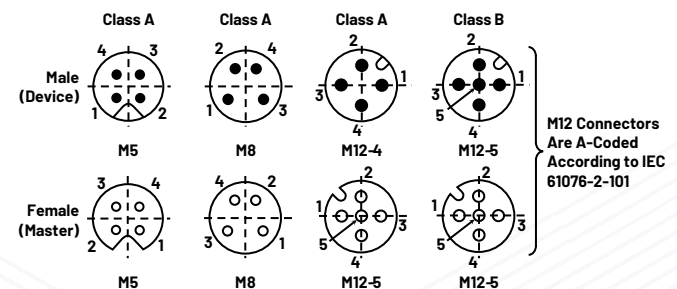

Figure 7. Alternative IO-Link connectors.

Physical Layer Electrical Specifications

The supply range in an IO-Link system is 20 V to 30 V for the master, or 18 V to 30 V for the device (sensor or actuator). Important related specifications (Table 3) include:

- ▶ A rising IO-Link signal must be above 13 V to be registered as a “logic high.”
- ▶ A falling IO-Link signal must be below 8 V to be registered as a “logic low.”

Note that the high and low detection time (t_H and t_L in the timing diagram) are 1/16 of a bit (minimum). t_{ND} is the noise suppression duration (t_{ND} must be less than 1/16 of a bit) (Figures 8a and 8b).

Communication uses a UART frame consisting of 11 bits = 1 start bit + 8 data bits + 1 parity bit + 1 STOP bit. Durations are defined by the transmission rate, which depends upon the device.

Table 3. IO-Link Signal Electrical Specifications

Property	Designation	Min	Typ	Max	Unit	Remark
$V_{THH_{D,M}}$	Input threshold ‘H’	10.5	N/A	13	V	See Note 1
$V_{THL_{D,M}}$	Input threshold ‘L’	8	N/A	11.5	V	See Note 1
$V_{HYS_{D,M}}$	Hysteresis between input thresholds ‘H’ and ‘L’	0	N/A	N/A	V	Shall not be negative. See Note 2
$V_{IL_{D,M}}$	Permissible voltage range ‘L’	$V_{O_{D,M}} - 1.0$	N/A	N/A	V	With reference to relevant negative supply voltage.
$V_{IH_{D,M}}$	Permissible voltage range ‘H’	N/A	N/A	$V_{+_{D,M}} + 1.0$	V	With reference to relevant positive supply voltage.

Note 1: Thresholds are compatible with the definitions of type 1 digital inputs in IEC 61131-2.
 Note 2: Hysteresis voltage $V_{HYS} = V_{THH} - V_{THL}$.

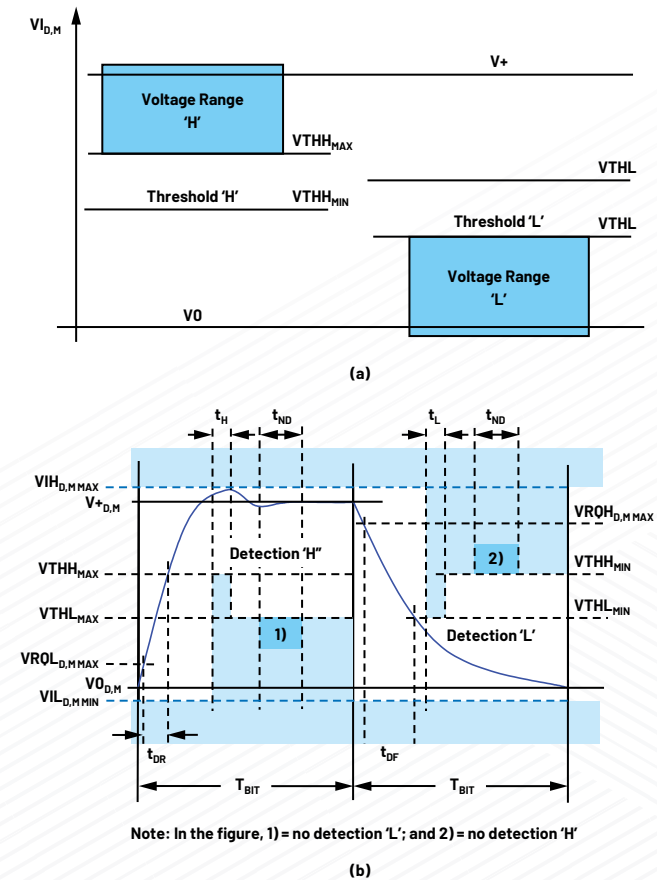

Figure 8. (a) IO-Link signal electrical thresholds; (b) IO-Link signal electrical characteristics.

IO-Link in the Automation Hierarchy

An IO-Link device is connected as a point-to-point link to a port in an IO-Link master. If implemented as a PLC plug-in module, it does not have gateway functionality and as such, is not a fieldbus. The IO-Link master is essentially a gateway, with responsibility for establishing communication using fieldbuses or some other type of backplane, enabling the IO-Link devices to become fieldbus I/O nodes (Figure 9).

IO-Link functionality in a system reduces maintenance, increases uptime, and transforms a manual sensor installation into one that allows a user to “plug-and-play and walk away.” The parameter settings can be downloaded from the controller to set up (or reconfigure) a device. This means a technician is no longer needed on the shop floor to do initial setup and machine downtime is reduced when it is required to reconfigure devices.

IO-Link allows for continuous diagnostics and improved data logging and error detection to further reduce operating costs. Commonly used connectors and cables enable standardized installation with direct binary sensor upgrades. Since IO-Link sensors have configurable settings (for example, PNP, NPN, or push-pull outputs that can be changed while in progress), the number of product units the sensor vendor needs to support is also reduced.

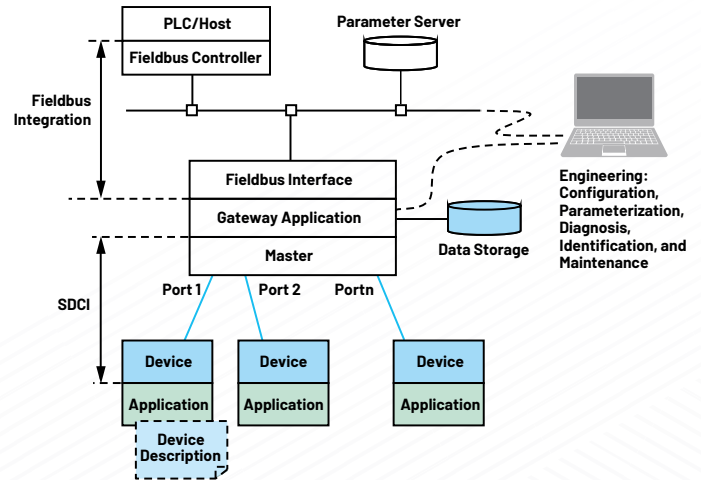

Figure 9. IO-Link fieldbus interconnection.

IO-Link – Enabling Intelligent Sensors

To summarize, IO-Link is a point-to-point connection that may be layered over any given network. As an integral part of the I/O module, the IO-Link master is installed either in the control cabinet or directly in the field as a remote I/O with an IP 65/67 enclosure rating. The IO-Link device is coupled with the master using a standard sensor/actuator cable measuring up to 20 meters in length. The device—which may be any sensor, any actuator, or a combination of the two—transmits and receives data (binary switching, analog, input, output) that are transmitted directly via IO-Link in a digital format.

IO-Link is very powerful and flexible, allowing some of the intelligence to be moved from the PLC closer to the sensors on the factory floor. For example, by using Pin 2 (I/Q) as a DI/DO, in addition to the C/Q line, the user can take in digital input signals from a binary sensor and then drive a lamp with the DO (to signify, for instance, if a threshold has been surpassed). This can be done from the sensor itself.

As mentioned, IO-Link is backward-compatible with SIO binary signals. With IO-Link-capable sensors, users communicate with existing PLCs through a standard digital input communication. As PLC modules are upgraded with an IO-Link master, bidirectional communication is enabled through the C/Q line on an IO-Link channel.

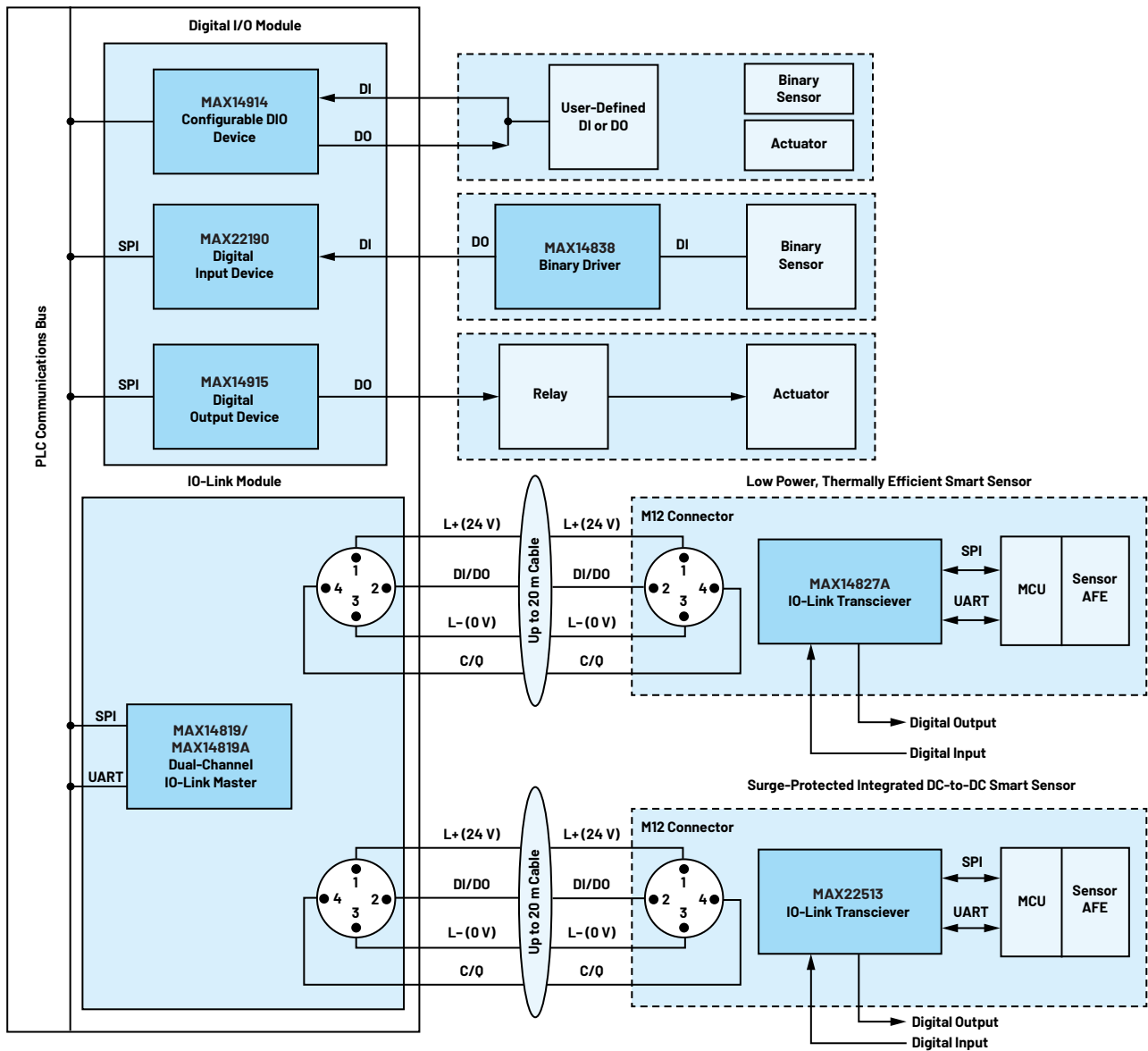

Figure 10. Industrial sensor ecosystem.

Industrial Sensor Ecosystem

Figure 10 shows an example of our industrial sensor ecosystem, which includes products for all key functions, including binary sensor output drivers, IO-Link devices, and IO-Link masters.

Section 2: IO-Link Environment

Data Link Layer

All IO-Link data exchange is master-device based, with the IO-Link master sending a request and the device required to answer. The data link layer manages the exchange of messages between the IO-Link master and device. Messages are called M-sequences, which are frames that have a length between 1 and 66 UART words. The messages can contain process data, on-request data, and system management commands/requests. A special DL handler in the master manages operating modes (SIO, wake-up, COM rates) and handles errors and wake-up requests.

The process data handler ensures the cyclical process data exchange while the on-request handler manages the acyclic exchange of event, control, parameter, and ISDU data.

Data Types

IO-Link data communication is either cyclic or acyclic (Figure 11). Cyclic communication occurs during normal operation. For example, the master requests sensing data from the sensor. Acyclic data is on-request and can contain:

- ▶ Configuration or maintenance information. For example, the master may configure the device after power-up or request the device configuration right before power-down.
- ▶ Event triggered, which is reported with three levels of severity:
 - Notifications
 - Warnings
 - Errors
- ▶ Service data for large data structures.
- ▶ Page data for direct reading of device parameters.

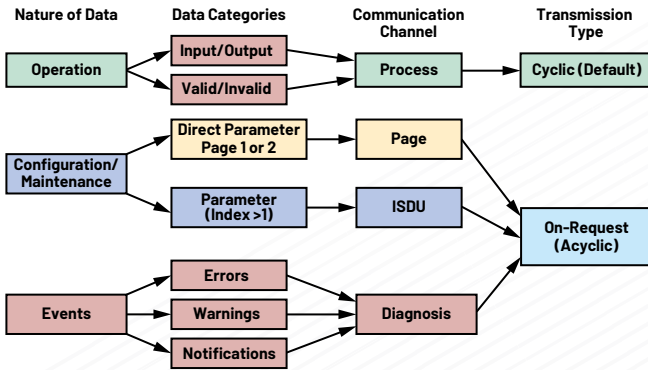

Figure 11. IO-Link transmission types.

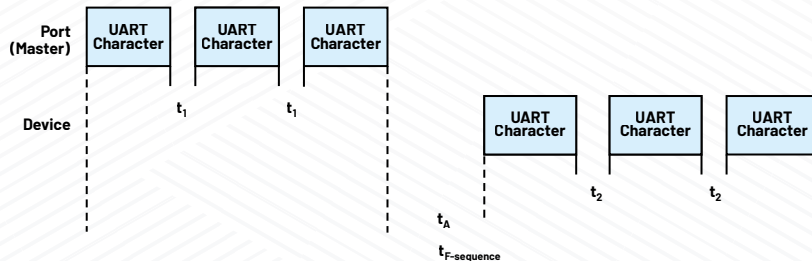

Figure 13. UART framing.

Master-Device Communication

All communication between the master and a device (sensor or actuator) begins with a request from the master and follows a fixed schedule (Figure 12). A device must answer all master requests. The sum of this back-and-forth communication is called an M-sequence (message sequence). An M-sequence can take many different forms and varies in total length. Although M-sequence communication may vary, all communication between a master and device takes place on this fixed schedule.

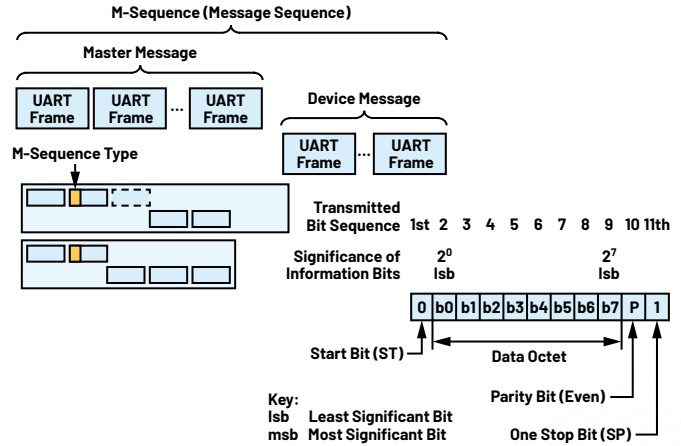

Figure 12. IO-Link master-device communication sequence.

UART Data on the C/Q Line

All data is UART framed. The master initiates communication and the device must answer within 1 TBit $\leq t_A \leq 10$ TBit intervals (Figure 13).

Wake-Up Request

When a master wants to configure a device (sensor or actuator) or communicate with it for the first time, it will send a wake-up request. A wake-up request starts by shorting the C/Q line for 80 μ s with a current pulse of at least 500 mA (Figure 14). The device must be ready for communication within 500 μ s (T_{REN}).

- ▶ A wake-up period is typically 80 μ s (75 μ s, min or 85 μ s, max).
- ▶ The master sources (or sinks) the current to generate the wake-up pulse. If the line is low, the master will source current to pull it high. If the line is high, the master will sink current to pull it low.
- ▶ The wake-up pulse is detected by the IO-link device (which either monitors the current on the line or detects a voltage change of low-to-high or high-to-low).
- ▶ When the wake-up request is received, the IO-Link device must configure itself to receive mode. This must occur within 500 μ s of receiving the request, or an error will be generated by the master.

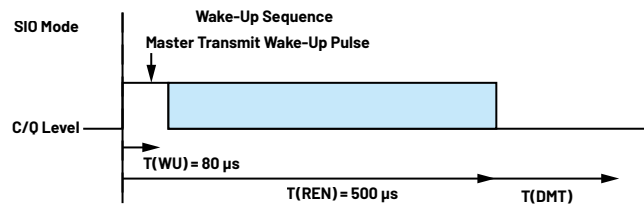

Figure 14. Wake-up sequence.

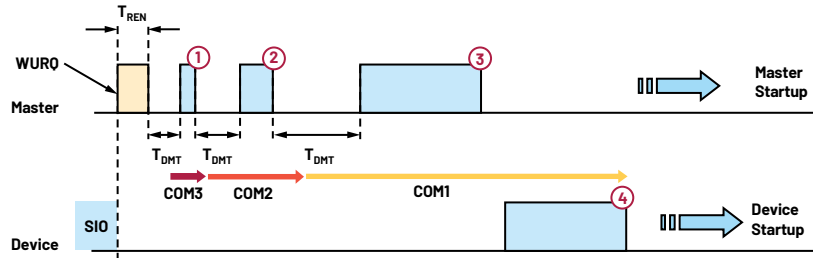

Figure 15. Data rate selection.

IO-Link Data Rate Selection

Once the master has sent a wake-up request to the device (to set it to receive mode), the master then learns more about it by establishing the data rate for communication (Figure 15):

- ▶ The master sends multiple messages at the COM3, COM2, and COM1 data rates (fastest to slowest), and waits for the device to respond after each send:
 - Any given device is required to support only one of the COM1, COM2, or COM3 data rates.
- ▶ The device will respond at its rated data rate:
 - When the device responds, the master is then able to communicate with the device.
 - The master can then read out the minimum cycle time capability of the IO-Link device.
- ▶ The master can retry the wake-up sequence a maximum of two times to establish IO-Link communication.
 - If the wake-up request fails, and then fails a second time (max retries = 2), the device must set the C/Q line to SIO (DI/DO binary sensor) mode.

The IO-Link IODD

All IO-Link devices (sensors or actuators) must have an associated IO-Link Device Description (IODD) file available (Figure 16). This is used by the IO-Link master for purposes of identification, data interpretation, and configuration.

- ▶ The IODD contains:
 - All necessary properties to establish communication
 - Device parameters
 - Identification information
 - Process and diagnostic information
 - An image of the device and the manufacturer's logo
- ▶ IODD files are XML files
- ▶ The structure of the IODD is outlined in a separate document from the IEC 61131-9 standard
- ▶ The IO-Link Consortium maintains a centralized, multivendor database for IODD files on the [IO-Link](#) website

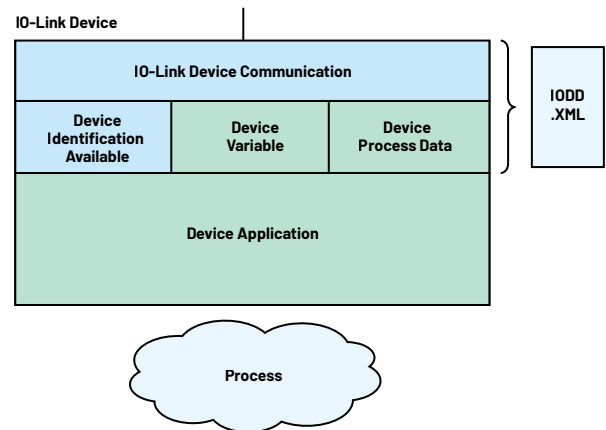

Figure 16. IODD file.

Section 3: Designing an IO-Link Sensor

In this section, we will look at reference design examples that demonstrate how to design a smart sensor system as well as a system to support legacy binary sensors that interface to an IO-Link port.

Sensor Design Considerations

The basic structure of an IO-Link sensor includes some fundamental building blocks (Figure 17a and Figure 17b) that the system designer must consider:

- ▶ Sensor type (optical, temperature, etc.)
- ▶ MCU that interfaces with the sensor and runs the IO-Link device stack
- ▶ IO-Link transceiver (or physical layer/PHY)
- ▶ Power supply and the various voltage and current ratings required
- ▶ Connector type
- ▶ External protection (TVS for surge, EFT/burst, ESD, etc.)

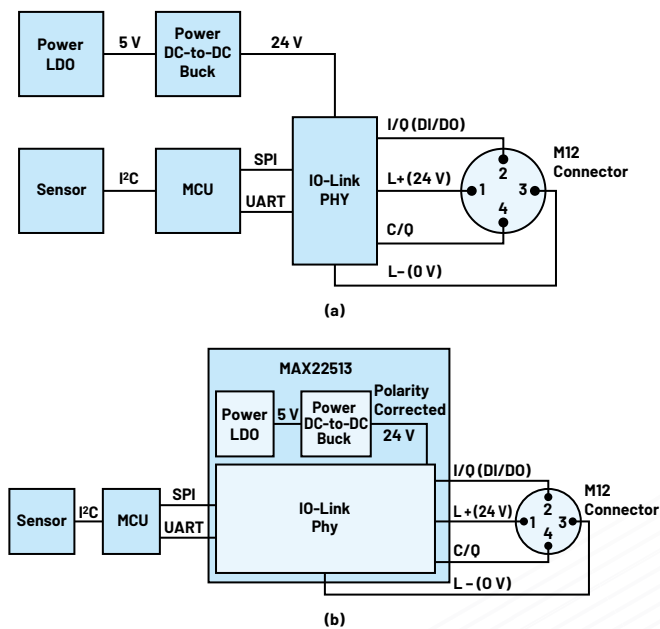

Figure 17. (a) Building blocks of an IO-Link sensor and (b) Building blocks of a highly integrated IO-Link sensor.

IO-Link Smart Sensor Design Features

Figure 18 shows the MAXREFDES164 temperature sensor and the MAXREFDES171 distance sensor. The MAXREFDES173 temperature sensor and the MAXREFDES174 distance sensor are also discussed in this section. These designs are compliant with IO-Link version 1.1 and 1.0 and include transient voltage suppression as well as reverse-polarity and short-circuit protection. For MAXREFDES164, the IO-Link transceiver is the single-channel MAX14828, which is very low power but requires external varistors for surge protection. The microcontroller used is the MAX32660 running a TMG or TEConcept stack. For MAXREFDES173, the IO-Link transceiver is the dual-channel MAX14827A and the microcontroller is a Renesas RL78 running an IQ² stack.

The MAXREFDES171 and MAXREFDES174 use the MAX22513 IO-Link transceiver, which features integrated surge protection (no external TVS required) as well as an integrated DC-to-DC buck converter, making it more efficient for higher powered sensors (such as distance sensors) that require a larger load current. The

use of the DC-to-DC buck compared to a linear regulator greatly improves the thermal performance of such a sensor. For MAXREFDES171, the microcontroller is the MAX32660 running a TMG stack while the MAXREFDES174's microcontroller is a Renesas RL78 running an IQ² stack.

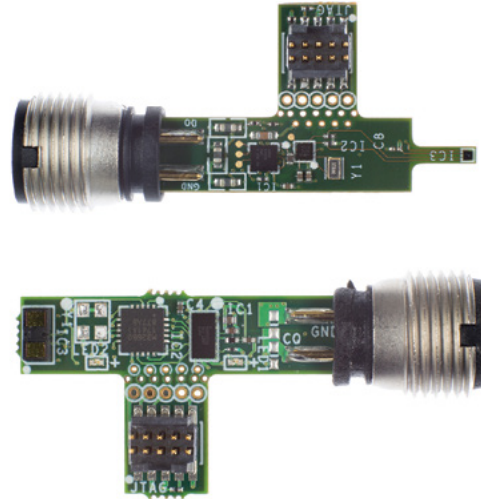

Figure 19. A MAXREFDES164 temperature sensor and MAXREFDES171 distance sensor.

IO-Link Temperature Sensor: MAXREFDES164 and MAXREFDES173

We have collaborated with Technologie Management Gruppe Technologie und Engineering (TMG TE) and TEConcept in designing the MAXREFDES164 as a temperature sensor reference design that is compliant with the IO-Link version 1.1.3/1.0 standard. The MAXREFDES164 design consists of an industry-standard ADI IO-Link device transceiver (MAX14828), a MAX32660 ultra low power 32-bit microcontroller utilizing TMG TE's or TEConcept's IO-Link device stack, and an ADI local temperature sensor (MAX31875). Figure 19 shows the system block diagram.

The MAXREFDES164 IO-Link local temperature sensor consumes minimal power, space, and cost, making it an all-around solution for many industrial control and automation local temperature sensing applications.

The MAX14828 IO-Link device transceiver is IO-Link version 1.1.3/1.0 physical layer-compliant and integrates the high voltage functions commonly found in industrial sensors, including drivers and regulators, all in a tiny 2.5 mm × 2.5 mm WLP package. The MAX14828 features two ultra low power drivers with active reverse-polarity protection. Operation is specified for normal 24 V supply voltages up to 60 V. Transient protection is simplified due to high voltage tolerance (65 V absolute maximum rating) allowing the use of varistors or micro TVS.

The MAX14828 features a flexible control interface. An SPI interface is available with extensive diagnostics, and for IO-Link operation, a three-wire UART interface is provided. The MAXREFDES164 takes advantage of the multiplexed UART/SPI option, which allows using one serial microcontroller interface for shared SPI and UART interfaces. The MAX14828 includes integrated 3.3 V and 5 V linear regulators that provide the low noise supply rails for the other components on the board.

The MAX32660 is an ultra low power, cost-effective highly integrated microcontroller that combines a flexible and versatile power management unit with the powerful Arm® Cortex®-M4 with floating point unit (FPU). The device integrates up to 256 kB of flash memory and 96 kB of RAM to accommodate application and sensor code. It supports SPI, UART, and I²C communication in a tiny 1.6 mm × 1.6 mm, 16-lead WLP.

The MAX31875 is a $\pm 1^{\circ}\text{C}$ -accurate local temperature sensor with I²C/SMBus interface. The combination of a tiny package and excellent temperature measurement accuracy makes this product ideal for a variety of equipment. The MAX31875 temperature sensor measures temperature and converts the data into digital form. An I²C-compatible two-wire serial interface allows access to conversion results. Standard I²C commands allow reading the data and configuring other operating characteristics. The MAX31875 is available in a 4-ball WLP and operates over the -50°C to $+150^{\circ}\text{C}$ temperature range.

For protection, the MAXREFDES164 uses varistors (MOV) at the IO-Link interface. The VC060330A650DP varistors have a working voltage of 30 V and a breakdown voltage of 41 V. With these varistors, this reference design meets both IEC 61000-4-2 (ESD) and IEC 61000-4-4 (EFT). It is designed to meet surge capability ($\pm 1 \text{ kV}/500 \Omega$ at $t = 1.2/50 \mu\text{s}$) and a low clamping voltage of $< 70 \text{ V}$. The MAX14828 absolute maximum (Abs Max) voltage rating of 65 V on the IO-Link pins allows the use of these tiny and simple varistors where other vendors' transceiver ICs (with lower Abs Max ratings) require much larger sized TVS diodes.

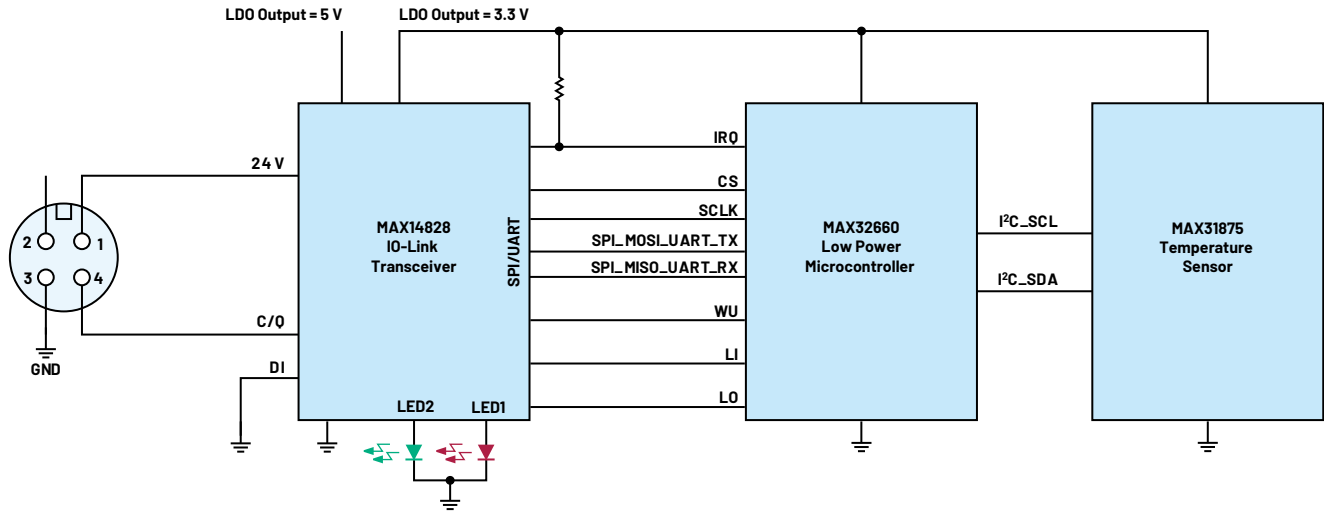

Figure 19. A MAXREFDES164 IO-Link temperature sensor block diagram.

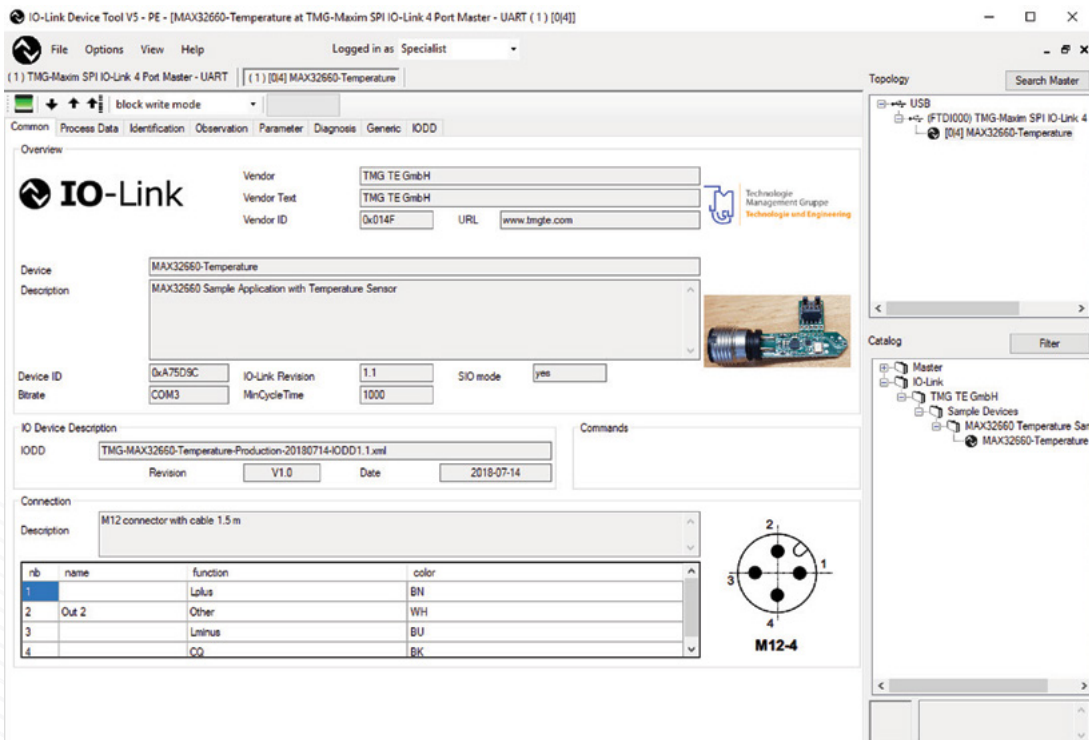

Figure 20. MAXREFDES164 IO-Link device software interface.

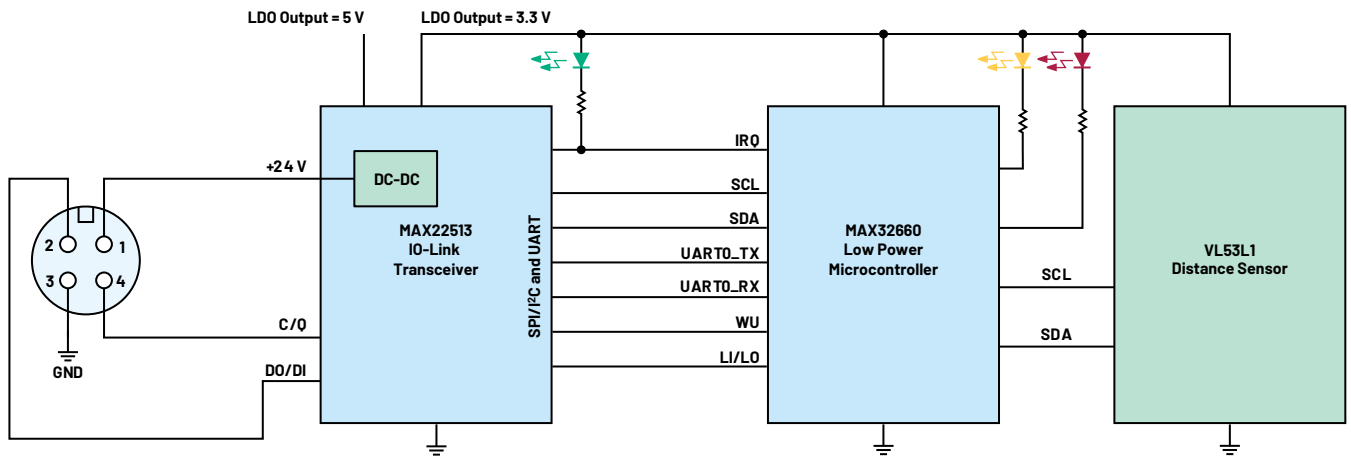

Figure 21. A MAXREFDES171 IO-Link device distance sensor.

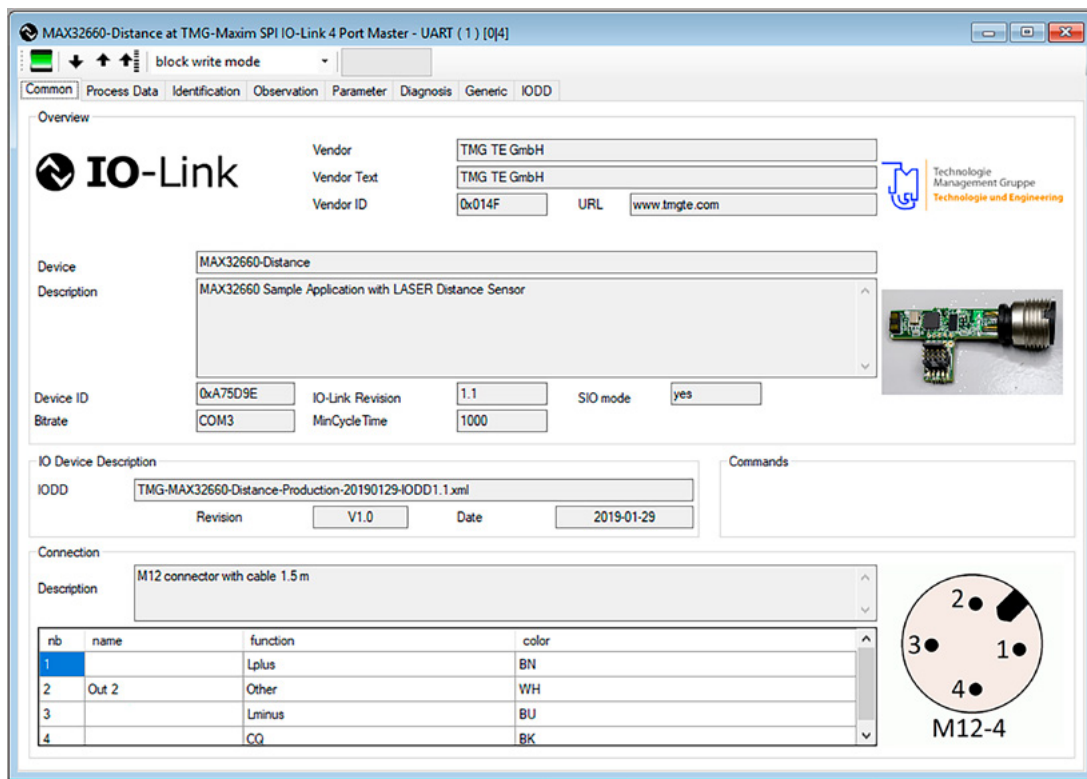

Figure 22. A MAXREFDES171 IO-Link device software interface.

The MAXREFDES164 uses an industry-standard M12 connector that allows the use of a 4-wire cable. The MAXREFDES164 consumes less than 6 mA (typ) including the green LED “alive signal,” which pulses rather than remains constantly on to reduce power consumption. Note the red LED, if illuminated, indicates a FAULT condition.

To demonstrate the performance of our IO-Link transceivers with different microcontrollers and stack software, the MAXREFDES173 implements a similar sensor but uses the MAX14827A IO-Link transceiver and Renesas RL78 with IQ² stack.

Description of Software

The MAXREFDES164 was verified using TMG TE’s IO-Link Device Tool V5 and our MAXREFDES165 4-port IO-Link master reference design. Download the IODD file (*.xml) located under the Design Resources section of the MAXREFDES164 product page and go to the Quick Start section for step-by-step instructions on how to use the software (Figure 20). Note: The MAXREFDES164 also works seamlessly with the MAXREFDES145 8-port IO-Link master and the TEConcept IO-Link Control Tool.

IO-Link Distance Sensor: MAXREFDES171 and MAXREFDES174

We have collaborated with Technologie Management Gruppe Technologie und Engineering (TMG TE) in designing the MAXREFDES171 (Figure 21) as a reference design that is compliant with the IO-Link version 1.1.3/1.0 standard. The MAXREFDES171 design consists of an industry-standard MAX22513 IO-Link device transceiver, a MAX32660 ultra low power 32-bit microcontroller that utilizes the TMG TE IO-Link device stack, and a commercially available time of flight (ToF) laser-ranging sensor.

The MAXREFDES171 IO-Link distance sensor consumes minimal power, space, and cost, making it a complete solution for distance and proximity sensing in many industrial control and automation applications.

The MAX22513 IO-Link device transceiver is compliant with the IO-Link version 1.1/1.0 physical layer specification. It integrates the high voltage functions commonly found in industrial sensors, including drivers, a high efficiency DC-to-DC buck regulator, and two linear regulators, all contained in a tiny 4.1 mm × 2.1 mm WLP. The MAX22513 features extensive integrated protection to ensure robust communication in harsh industrial environments. All four I/O pins (V24, C/Q, DO/DI, and GND) are reverse-voltage and short-circuit protected, and feature an integrated ±1 kV/500 Ω surge protection. This enables a very small PCB area with no required external components (such as TVS diodes). The low on-resistance drivers (C/Q and DO/DI) further reduce power dissipation, allowing the reference design to consume minimal power and have very low thermal dissipation. Operation is specified for the typical 24 V supply and operates with voltages up to 36 V. Transient protection is simplified due to high voltage tolerance (65 V absolute maximum rating) in addition to the integrated surge protection.

The integrated DC-to-DC buck regulator significantly reduces system power dissipation by dropping the available 24 V to a lower voltage more efficiently than a linear regulator. The two integrated LDO regulators within MAX22513 generate 3.3 V and 5 V, saving external components and space. The DC-to-DC regulator can provide 300 mA at low voltages much more efficiently than an LDO regulator, making this transceiver ideal to power high current sensors.

The MAX22513 features a flexible control interface, allowing control through either an SPI or I²C interface. In this design, we use I²C to reduce the number of pins required by the microcontroller. I²C allows both the MAX22513 and the sensor IC to be on the same bus. The I²C (or SPI) interface provides extensive diagnostics (from MAX22513), and a 3-wire UART interface is provided for IO-Link communication.

The MAX32660 is an ultra low power, cost-effective, highly integrated microcontroller that combines a flexible and versatile power management unit with the powerful Arm Cortex-M4 with FPU. The device integrates up to 256 kB of flash memory and 96 kB of RAM to accommodate application and sensor code. It supports SPI, UART, and I²C communication in a tiny, 1.6 mm × 1.6 mm, 16-lead WLP.

The VL53L1X is a ToF, laser-ranging sensor that provides accurate distance that ranges up to 400 cm. The ranging sensor is programmed with firmware and is controlled by a simple I²C interface that only requires SCL and SDA. The module does not have a cover for the receiving lens, so care needs to be taken to keep the lens clean; otherwise, distance measurement performance will be impacted. The VL53L1X is in a small, 4.9 mm × 2.5 mm × 1.6 mm module and operates over the -20°C to +85°C temperature range. This is the limiting item for the reference design operating temperature range, as the MAX22513 IO-Link transceiver operates over the -40°C to +125°C temperature range.

The MAXREFDES171 does NOT require external devices such as varistors or TVS diodes for protection due to the integrated surge protection within MAX22513 at the IO-Link interface. This reference design meets both IEC 61000-4-2 (ESD) and IEC 61000-4-4 (EFT) standards. It is also designed to meet surge capability (up to ±1 kV/500 Ω at t = 1.2/50 μs) and has a low clamping voltage of < 70 V.

The MAXREFDES171 uses an industry-standard M12 connector, allowing a 4-wire cable to be used.

To demonstrate the performance of ADI's IO-Link transceivers with different microcontrollers and stack software, the MAXREFDES174 implements a similar sensor but uses a Renesas RL78 microcontroller with IQ² stack.

Description of Software

The MAXREFDES171 was verified using TMG TE's IO-Link Device Tool V5 and our MAXREFDES165 4-port IO-Link master. Download the IODD file (*.xml) located in the Download All Design Files section of the MAXREFDES171 product page's Design Resources tab. Go to the Quick Start section for step-by-step instructions on how to use the software. Figure 22 shows a screenshot of the TMG TE IO-Link Device Tool.

For complete details of each reference design, including full design files please visit analog.com.

IO-Link 16-Channel Digital Input Hub: MAXREFDES176

The MAXREFDES176# is a complete, IO-Link 16-channel digital input hub reference design that consists of a MAX22515 IO-Link transceiver with integrated protection. It demonstrates an isolated digital input hub using the MAX22192 isolated octal digital input device daisy-chained with the MAX22190 octal digital input device to provide a total of 16 digital input channels.

Type 1 and Type 3 sensors are supported by default. Type 2 sensors can also be supported by modifying the resistor value that controls the value of the current sink within the devices. Built in an industrial form factor, the MAXREFDES176# uses an industry-standard M12 connector, allowing a 4-wire cable to be used. The digital input channels use industry-standard PCB terminal blocks.

In this design, an Atmel® ATSAM low power microcontroller interfaces between the MAX22192 isolated digital input serializer and the MAX22515 IO-Link device transceiver. The MAX22515 features integrated surge protection for robust communication in a very small PCB area without requiring external protection components, such as TVS diodes. The MAX22515 is available in a tiny 20-ball WLP package, allowing the MAXREFDES176# to have a small footprint, though this is mostly determined by the size of the connectors. The design is reverse-polarity protected using the integrated active reverse-polarity protection of the MAX22515. The MAX22515 has two integrated LDO regulators (3.3 V and 5.0 V). The 3.3 V LDO regulator is used to generate the 3.3 V supply for other circuitry, reducing the number of required external components and further saving space. The MAX22515 also features low on-resistance drivers (C/Q and DO/DI) to reduce power dissipation, allowing this reference design to consume minimal power with very low thermal dissipation.

This IO-Link device utilizes the Technologie Management Gruppe Technologie und Engineering (TMG TE) IO-Link device stack to communicate to any IO-Link version 1.1-compliant master. The board contains a male M12 connector for connecting to a compliant IO-Link master using a standard M12 cable. Connecting the MAXREFDES176# to a USB IO-link master, such as the MAXREFDES165#, with the associated software allows for easy evaluation.

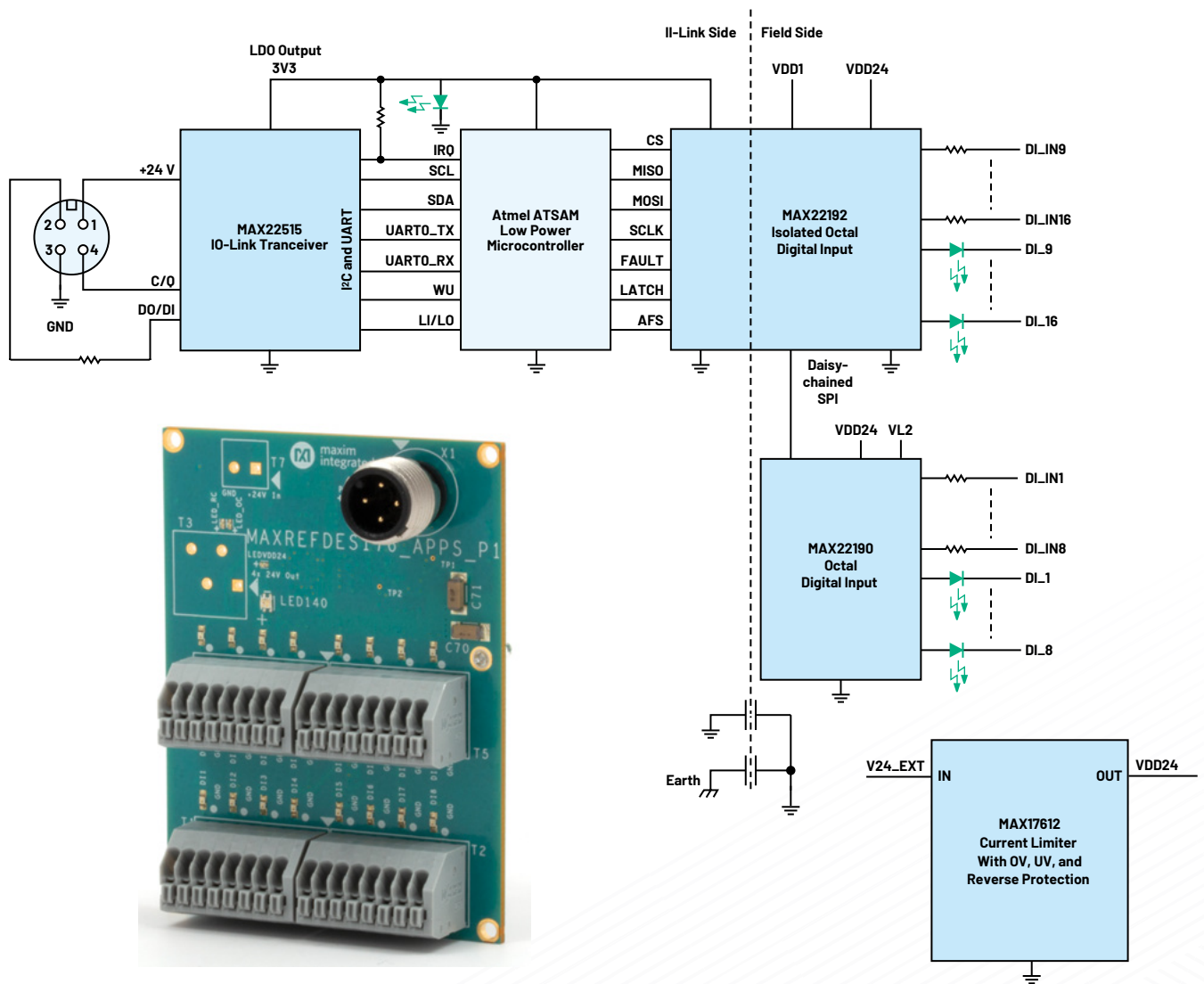

Figure 23. MAXREFDES176 digital input concentrator.

IO-Link Universal Analog IO: MAXREFDES177

The MAXREFDES177# is a complete, IO-Link universal analog input-output reference design that has a MAX22515 IO-Link transceiver with integrated protection. It demonstrates a fully software-configurable analog IO module using the MAX22000 industrial configurable analog I/O device. The analog (field) side is fully isolated from the IO-Link side with the MAX14483 digital data isolator and an isolated power supply derived from the L+ (24 V) supply from the IO-Link master connection.

The MAXREFDES177#, built in an industrial form factor, uses an industry-standard M12 connector with a 4-wire IO-Link cable. The analog (field) side uses a 4-way PCB terminal block. The complete reference design fits on a 61 mm × 25 mm printed circuit board (PCB).

The configurable modes include analog voltage input (± 10 V), analog current input (± 20 mA), analog voltage output (± 10 V), and analog current output (± 20 mA) across the AIO and GND terminals. The MAXREFDES177# sets the linear range at 105% and full-scale range at 125% of the nominal range. The accuracy is as good as 0.1% over a $\pm 50^\circ\text{C}$ temperature variation. The other two terminals can be configured to measure temperature using a standard device such as a PT100 or PT1000 RTD. These terminals interface to the integrated programmable gain amplifier (PGA) in the MAX22000 at inputs AI5 and AI6.

An Atmel ATSAM low power microcontroller interfaces between the MAX22000 industrial configurable analog I/O device and MAX22515 IO-Link device transceiver. The MAX22515 features integrated surge protection for robust communication in a very small PCB area without requiring external protection components such as TVS diodes. The MAX22515 is available in a tiny 20-ball wafer-level package (WLP), allowing the MAXREFDES177# to have a small footprint. The design is reverse-polarity protected using the integrated active reverse-polarity protection of the MAX22515. The MAX22515 has two integrated LDO regulators (3.3 V and 5 V). The 3.3 V LDO regulator generates the 3.3 V supply for other circuitry, reducing the number of required external components and saving space. The MAX22515 also

features low on-resistance drivers (C/Q and DO/DI) to reduce power dissipation, allowing this reference design to consume minimal power with very low thermal dissipation.

This IO-Link device utilizes the Technologie Management Gruppe Technologie und Engineering (TMG TE) IO-Link device stack to communicate to any IO-Link version 1.1-compliant master. The board contains a male M12 connector to connect to a compliant IO-Link master using a standard M12 cable. Connecting the MAXREFDES177# to a USB IO-link master, such as the MAXREFDES165#, with the associated software allows for easy evaluation.

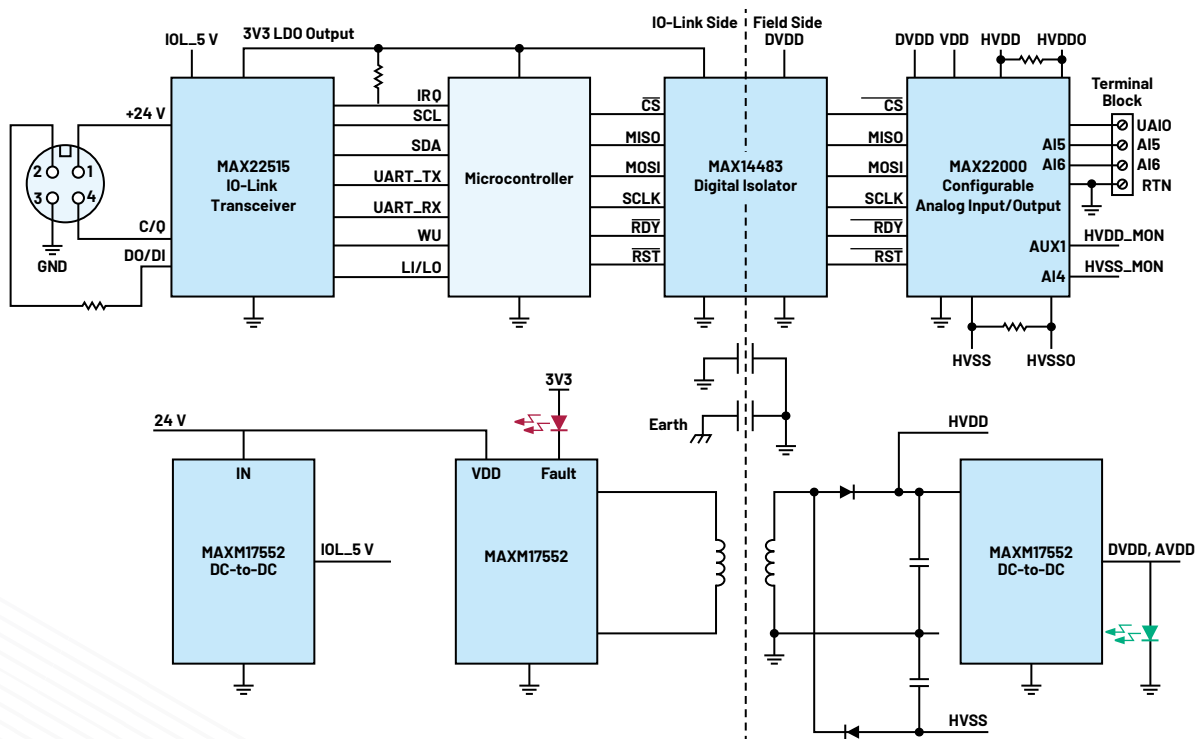
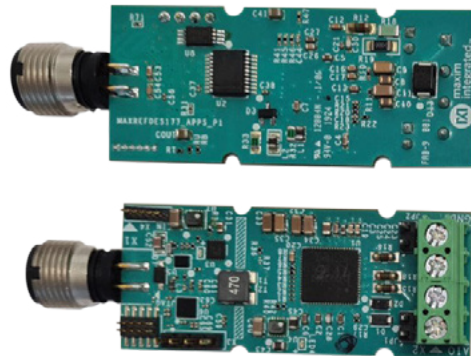

Figure 24. MAXREFDES177 universal analog I/O.

IO-Link to Pmod-Compatible Adapter: MAXREFDES281, MAXREFDES284

The MAXREFDES281# and MAXREFDES284# are a complete, IO-Link reference design that allows an engineer to connect device or actuator development boards with a pmod™-compatible peripheral module connector, and interface to an IO-Link Master. The MAX22516 (coming spring 2023) features an integrated data link controller that significantly simplifies the IO-Link communication timing requirements with independent buffers for PDI_n, PDI_o, and ISDU transfers. The microcontroller can read or write to/from the buffers as the application allows, independent from the IO-Link master timing.

The MAXREFDES281# consists of a MAX22516 IO-Link transceiver with integrated data link controller and protection, an STM microcontroller to run application code, and has a peripheral module connector to connect device or actuator functions, supporting SPI, I²C, or UART interfaces. The complete reference design fits on a 75 mm × 33 mm printed circuit board (PCB).

The MAXREFDES284# consists of a MAX22516 IO-Link transceiver with integrated data link controller and protection, as well as a MAX32660 microcontroller to run application code, and has a peripheral module connector to connect device or actuator functions, supporting SPI, I²C, or UART interfaces. The complete reference design fits on a 75 mm × 33 mm printed circuit board (PCB).

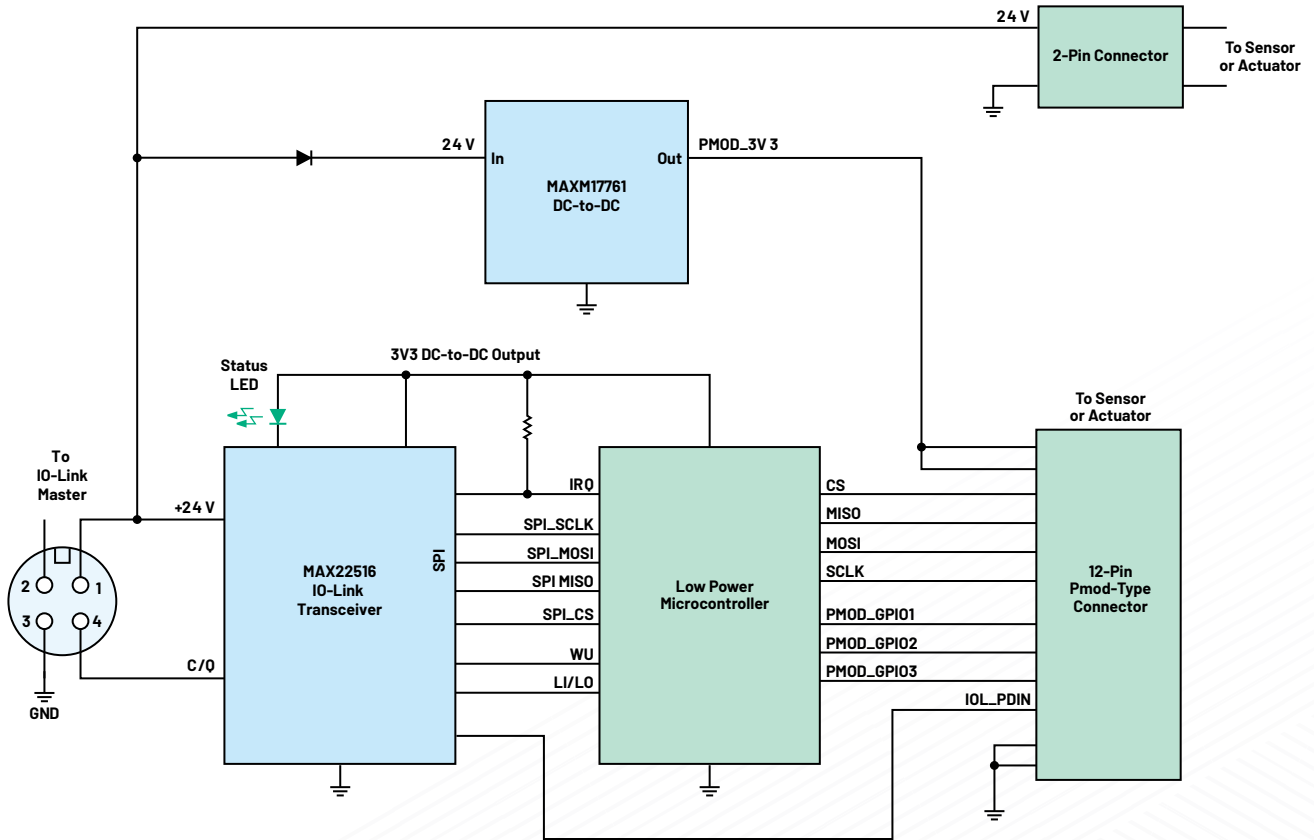

Figure 25. A MAXREFDES281#/MAXREFDES284# system block diagram.

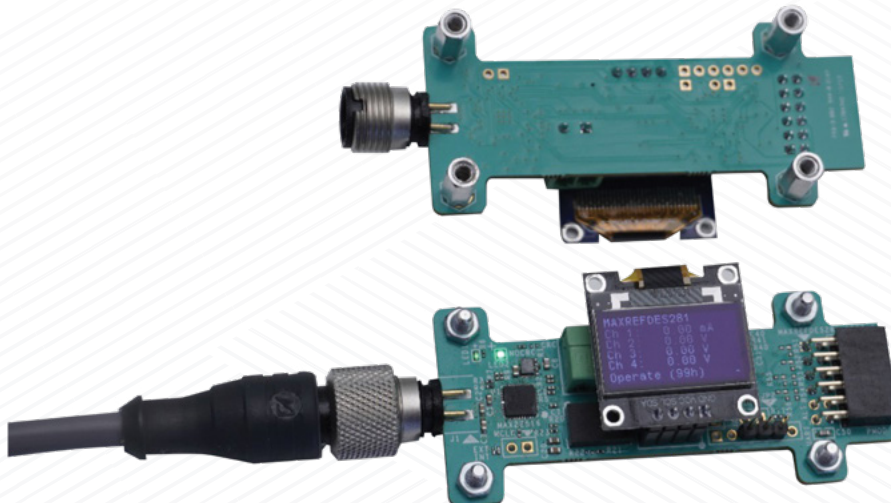

Figure 26. A MAXREFDES281#/MAXREFDES284# IO-Link to peripheral module device.

Section 4: Designing an IO-Link Actuator

As well as smart sensors, Industrial 4.0 automation requires smart solenoids and intelligent actuators. From traditional drives to intelligent actuators, there's a need for more flexibility of factories and automation equipment to adapt on-the-fly to the actual requirements. From ramping up production to completely changing equipment's function, more and more devices require adjustments to keep up with actual demand. This requires intelligence at the edge, where devices connect with the real world, to unlock a new level of real-time flexibility. Key to this is IO-Link, which allows traditional sensors and actuators to become intelligent and change the way we think.

Analog Devices provides IO-Link transceivers, smart actuator ICs, reference designs, and complete PANdrive™ solutions.

IO-Link 8-Channel Solenoid Actuator: MAXREFDES278

The **MAXREFDES278#** is a complete IO-Link 8-channel solenoid actuator reference design based on a **MAX22514** IO-Link transceiver with integrated protection. It demonstrates an 8-channel solenoid actuator using the **MAX22200** 1 A octal integrated serial-controlled solenoid driver with integrated FETs. This reference design has two power options: it can be powered either through the IO-Link master directly, delivering up to 800 mA total load, or for higher currents external power can be provided using an external source. To make sure no current flows back to the IO-Link master, and the IO-Link portion is always powered, this design uses the **MAX17608** current limiter with overvoltage (OV), undervoltage (UV), and reverse protection.

Built in an industrial form factor, and measuring just 85 mm × 42 mm, the **MAXREFDES278#** uses an industry-standard M12 connector, allowing a 4-wire IO-Link cable to be used. Each individual solenoid channel has its own 2-way terminal block.

In this design, an STM32 low power microcontroller interfaces between the **MAX22200** octal solenoid driver and the **MAX22514** IO-Link device transceiver. The **MAX22514** features integrated surge protection for robust communication in a small printed circuit board area without requiring external protection components such as transient voltage suppressor diodes. The **MAX22514** is available in a tiny 25-ball wafer-level package as well as a 24-lead TQFN package, allowing the **MAXREFDES278#** to have a small footprint. The design is reverse-polarity protected using the integrated active reverse-polarity protection of the **MAX22514**. The **MAX22514** has an integrated DC-to-DC converter as well as two integrated low dropout regulators (3.3 V and 5.0 V). The DC-to-DC converter is used to generate the 3.3 V supply for the microcontroller as well as the **MAX22200** logic supply, reducing power dissipation as well as the number of external components required, saving space and cost. The **MAX22514** also features a low on-resistance C/Q driver to reduce power dissipation, allowing this reference design to consume minimal power with very low thermal dissipation.

This IO-Link device utilizes the Technologie Management Gruppe Technologie und Engineering (TMG TE) IO-Link device stack to communicate to any IO-Link version 1.1-compliant master. The board contains a male M12 connector for connecting to a compliant IO-Link master using a standard M12 cable. Connecting the **MAXREFDES278#** to a USB IO-link master, such as the **MAXREFDES165#** or **MAXREFDES145#**, with the associated software allows for easy evaluation.

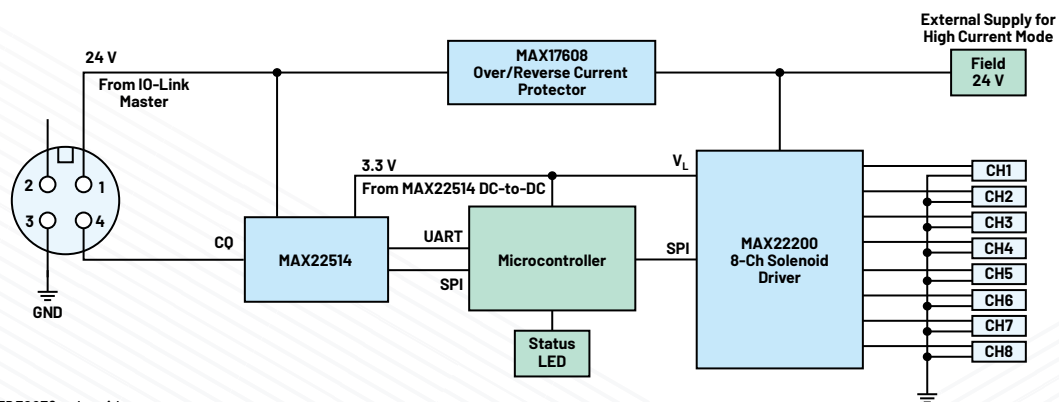
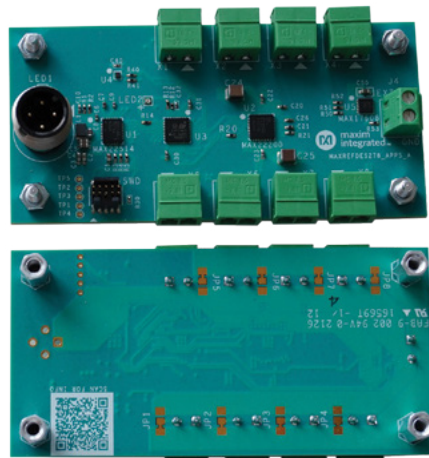

Figure 27. A MAXREFDES278 solenoid actuator.

PD-42-1-1243 IOLINK

The [PD42-1-1243-IOLINK](#) is a small, easy to use mechatronic PANdrive IO-Link actuator device. It combines a NEMA-17 stepper motor with controller and driver electronics. The IO-Link connection through a standard 4-pin M12 connector offers full control over the NEMA-17 stepper motor as well as provide an industry-standard IO Link communication protocol to enable control, configuration, and status monitoring.

The new chipset solution of the TMC2130-LA and MAX22513 builds upon the benefits of IO-Link's two-way universal interface. The intelligent actuator, which combines industry-leading motion control technology into a plug and play solution, is 2.6× smaller and more than 50% lower power compared to the competitive solution. It brings intelligence to the factory floor by providing 50% more parameters to help improve predicting factory shutdown in advance and maximizes factory throughput.

Pair the intelligent actuator with the MAXREFDES165# 4-channel IO-Link master reference design for a complete IO-Link solution.



Figure 28. PD42-x-1243 IO-Link PANdrive.

TMCM-1617-GRIP-REF

The [TMCM-1617-GRIP-REF](#) is an open-source hardware reference design for the TMCM-1617 BLDC servo driver. To be used in robotic gripper applications, the board is designed in a standard gripper electronics form factor. It is able to control a BLDC motor via EtherCAT®, IO-Link, or RS-485 using the ADI Trinamic TMCL protocol. In addition, the board features one configurable analog output and one configurable analog input, using ADI's MAX22000 industrial configurable analog I/O device and four configurable digital input, digital outputs, using ADI's [MAX14906](#) device.

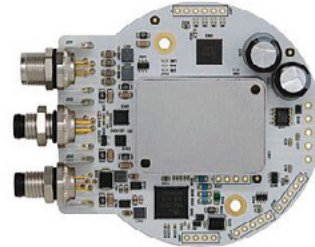

Figure 29. A TMCM-1617-GRIP-REF open-source hardware reference design.

Section 5: Designing an IO-Link Master

In this section, we will look at reference design examples that demonstrate how to design a multiport master for a smart sensor system using IO-Link.

IO-Link Master Design Objectives

When designing an IO-Link master solution, there are common system design questions that must be considered:

Hardware Design:

- ▶ How many IO-Link ports should the system have?
- ▶ Should the ports be Class A or Class B?
- ▶ Should the connectors in a Class A port support Pin 2?
- ▶ What miswiring cases should be accommodated for overvoltages or reverse polarity?
- ▶ Should the PCB design be modular and able to accommodate different port counts?
- ▶ How much current should the L+ supply provide?
- ▶ What is the form factor?

EMC Compliance:

- ▶ Who will perform the compliance testing?

As an example, our design team for the MAXREFDES145 eight-port IO-Link master reference design chose to create an 8-port master due to the popularity of the configuration and to provide an alternative to their existing 4-port master. They used the MAX14819A dual-channel IO-Link master transceiver and the STM32F4 Arm Cortex-M4 microcontroller, implementing isolation between the USB interface and the IO-Link channels. The reference design fits on a single 5" × 3" PCB. For software, the design team partnered with TEConcept, who supplied the IO-Link-compliant software stack and performed the compliance testing. The design includes a TVS diode at each of the IO-Link ports, and is tested to IEC 610004-2 and IEC 610004-5 for transient immunity to ESD and surge immunity.

8-Port IO-Link Master: MAXREFDES145

The MAXREFDES145 is a fully IO-Link-compliant, eight-port IO-Link master reference design (Figure 30). This design uses TEConcept's IO-Link master stack and is both an IO-Link master reference design as well as an IO-Link sensor/actuator development and test system. Eight IO-Link ports allow for simultaneous testing of up to eight different sensors (or actuators). The reference design has eight robust female M12 connectors, the most common connector used for IO-Link, and ships with two black IO-Link cables to quickly connect to IO-Link-compatible sensors and actuators. An AC-to-DC (24 V_{DC}/3 A) power supply provides at least 125 mA simultaneously to each port (more when fewer ports are used). A micro-USB connector allows for quick connectivity to a Windows® PC.

The easy to use TEConcept Control Tool (CT) GUI software, with IODD file import capability, makes the MAXREFDES145 a must-have for any company or engineer serious about developing IO-Link products.

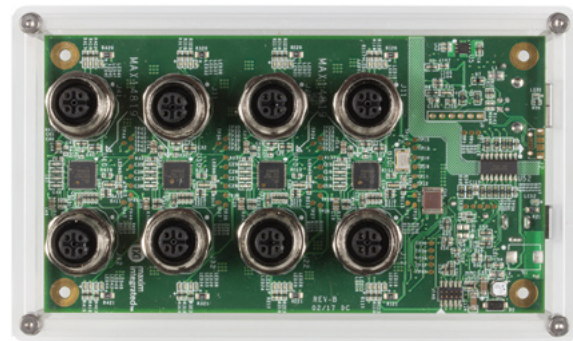

Figure 30. A MAXREFDES145 8-Port IO-Link Master reference design.

Description of Hardware

The MAXREFDES145 IO-Link master consists of four main blocks: four dual-channel MAX14819A IO-Link master transceivers, two digital isolators for the SPI interface, a microcontroller, and a USB connection as shown in Figure 31. The MAX14819A IO-Link master transceivers are IO-Link version 1.1.2 physical layer-compliant. These transceivers feature integrated 5 V linear regulators, configurable C/O outputs (push-pull, high-side, or low-side) with configurable output drive capability, auxiliary digital inputs, and reverse-polarity/overvoltage or short-circuit protection.

An STM32F4 Arm Cortex-M4 microcontroller provides system control. A USB port is implemented using the FTDI FT2232 USB-to-SPI transceiver and driver. An on-board MAX15062 high voltage, synchronous step-down converter provides power to the STM32F4 microcontroller from the 24 V supply. Two digital isolators, the four-channel MAX14931 and the two-channel MAX12931, protect the USB interface from high voltage and large ground differentials that may occur when the MAX14819A master transceivers are connected to IO-Link peripherals. All communication between the USB port/PC and the STM32F4 microcontroller passes through these isolators. A standalone SPI header (J3) is available on the MAXREFDES145 to allow the user to bypass the USB interface or directly communicate with the STM32F4 using an external SPI master.

High level protection TVS diodes at each of the eight IO-Link interface ports and at the power-supply inputs provide 1 kV/42 Ω surge and reverse-polarity protection for each master transceiver on the MAXREFDES145. Additionally, power and status LEDs (for each channel) provide quick visual confirmation that the board is working and communicating.

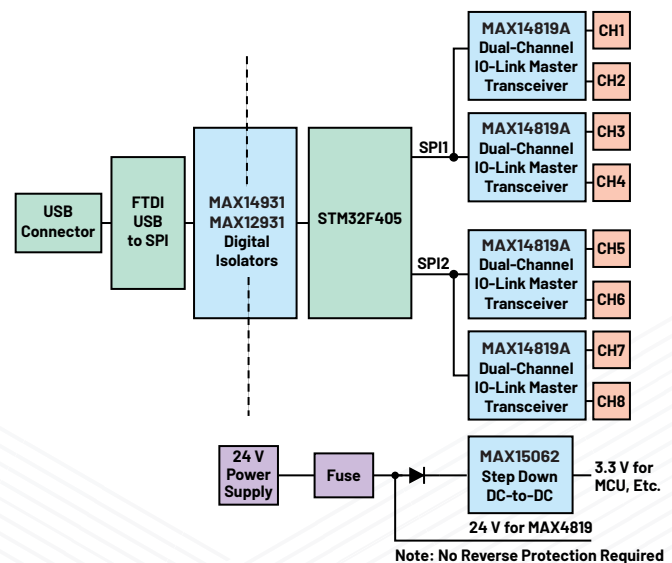

Figure 31. A MAXREFDES145 8-Port IO-Link master block diagram.

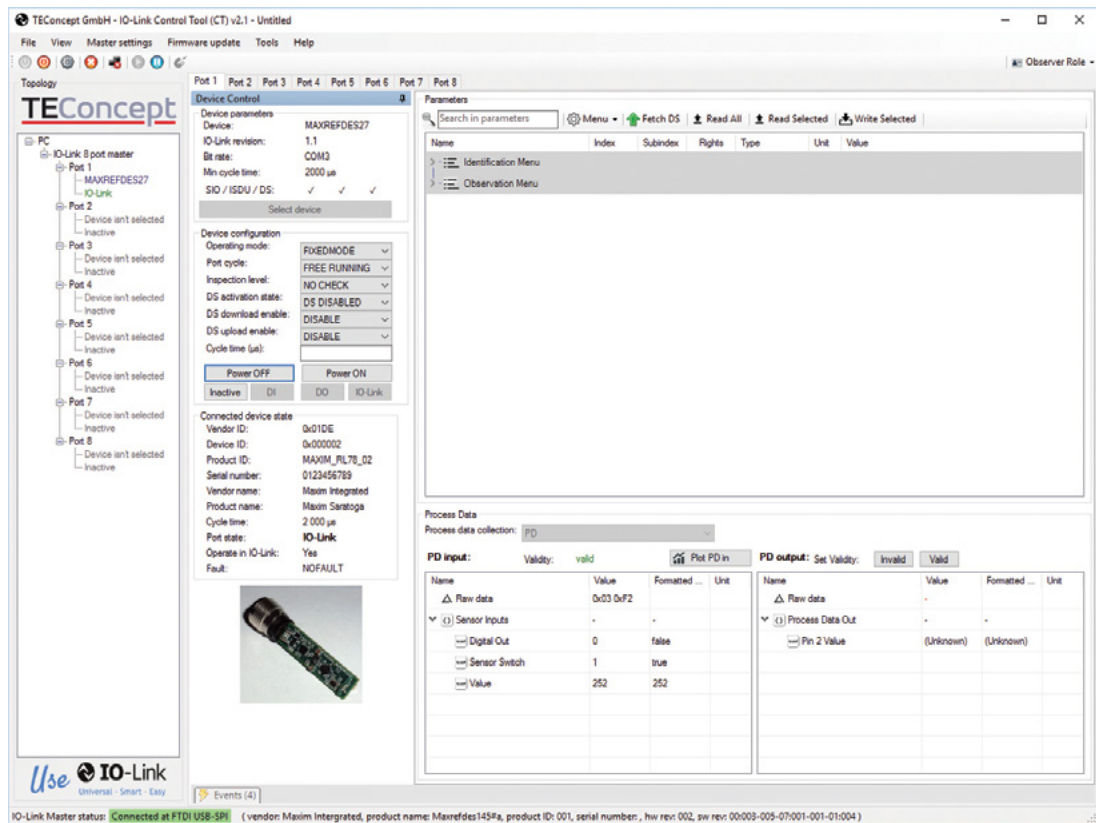

Figure 32. TE Concept IO-Link software.

Description of Software

The TEConcept CT Windows-compatible GUI software features IODD file import capability, connects to a PC via USB, and is available for download from the Design Resources tab of the MAXREFDES145 product page. The TEConcept CT software is shown in the Details tab of the MAXREFDES145's product page and a complete step-by-step Quick Start guide is also downloadable from the MAXREFDES145's Design Resources tab.

The TEConcept IO-Link master stack ships preprogrammed inside the MAXREFDES145 hardware with a perpetual time license displayed by the TEConcept CT software. This allows MAXREFDES145 to be used for development and testing purposes. Users wishing to design their own products can purchase firmware for the IO-Link master from TE-Concept. [Appendix of Technical Resources](#).

4-Port IO-Link Master: MAXREFDES165

The MAXREFDES165 (Figure 33) is a fully IO-Link-compliant, 4-port IO-Link master reference design. This design uses the TMG TE IO-Link master stack and is both an IO-Link master reference design and a development and test system for IO-Link sensors/actuators. Four IO-Link ports allow for simultaneous testing of up to four different sensors (or actuators). The reference design has four robust female M12 connectors—the most common connector used for IO-Link—and ships with an IO-Link cable for connecting quickly to IO-Link-compatible sensors and actuators. An AC-to-DC (24 V_{DC}/3 A) power supply can provide at least 250 mA to each port simultaneously, and more when fewer ports are used. A USB 2.0 Type B connector allows for quick connectivity to a Windows PC.



Figure 33. A MAXREFDES165 4-Port IO-Link master reference design.

Description of Hardware

The MAXREFDES165 IO-Link master comprises of four main blocks: two dual-channel MAX14819A IO-Link master transceivers, a MAX14931 digital isolator for the SPI interface, a microcontroller, and a USB connection (shown in Figure 34).

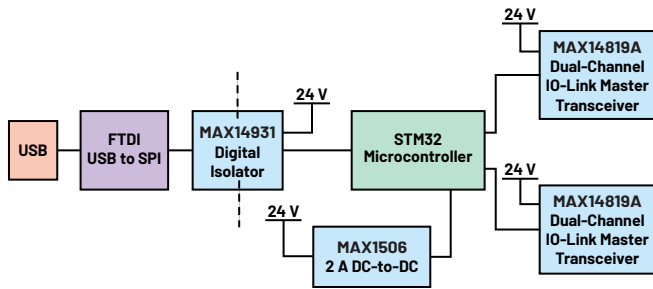

Figure 34. A MAXREFDES165 reference design block diagram.

The MAX14819A IO-Link master transceivers are IO-Link version 1.1.2 physical-layer compliant. These transceivers feature integrated 5 V linear regulators, configurable C/Q outputs (push-pull, high-side, or low-side) with configurable output drive capability, auxiliary digital inputs, and reverse-polarity/short-circuit protection.

An STM32F4 Arm Cortex-M4 microcontroller in a 10 mm × 10 mm, 64-lead LQFP package provides system control. A USB port is implemented using the FTDI FT232 USB-to-SPI transceiver and driver. An on-board MAX15062A high voltage, synchronous step-down converter provides power to the STM32F4 microcontroller from the 24 V supply.

A digital isolator, the four-channel MAX14931F, protects the USB interface from high voltage and large ground differentials that can occur when the MAX14819A master transceivers are connected to IO-Link peripherals. All communication between the USB port/PC and the SMT32F4 microcontroller passes through this isolator.

A standalone SPI header (J3) is available on the MAXREFDES165 to allow the user to bypass the USB interface and communicate directly with the STM32F4 using an external SPI master. J3 is connected to the isolated side of the board and all

digital communication from the external master to the STM32F4 goes through the isolators. An external 3.3 V logic supply is required to power the isolators when using J3. High level protection transient voltage suppressor (TVS) diodes at each of the four IO-Link interface ports and at the power supply inputs provide surge and reverse-polarity protection for each master transceiver on the MAXREFDES165.

Additionally, power and status LEDs (for each channel) provide quick visual confirmation that the board is working and communicating. The complete system block diagram is shown in Figure 34.

Note: The MAX14819A can be configured to operate with a UART interface (within the microcontroller) or by using the integrated framers on the IC. The advantage of the framer mode includes enabling support from smaller and lower cost microcontrollers with a limited number of integrated UARTs. The default stack that ships with the MAXREFDES165 is the UART version. If you require the Framer version, please contact the factory.

Description of Software

TMG's IO-Link Device Tool Windows-compatible software features IODD file import capability, connects to a PC through USB, and is available on request from TMG. The TMG IO-Link Device Tool software is shown in Figure 35, and a complete step-by-step Quick Start guide is also downloadable from the Design Resources tab.

Note: The MAX14819A can be configured to operate with a UART interface (within the microcontroller) or by using the integrated framers on the IC. The default stack that ships with the MAXREFDES165 is the UART version. If you require the Framer version, please contact the factory.

The TMG TE IO-Link master stack ships preprogrammed inside the MAXREFDES165 hardware with a perpetual license. Contact information for TMG TE GmbH is found in the list of Software Stack Vendors in the IO-Link Handbook's [Appendix of Technical Resources](#).

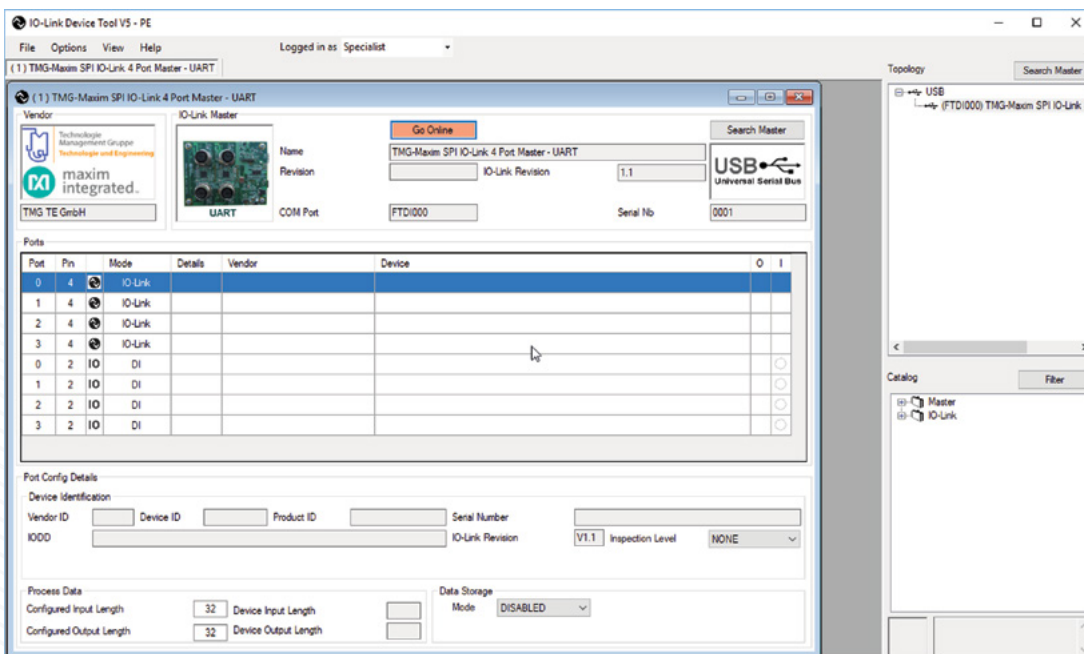

Figure 35. MAXREFDES165 TMG IO-Link Device Tool.

IO-Link 2-Channel Master in Pmod-Compatible Form Factor: MAXREFDES277

The MAXREFDES277# is a dual-channel IO-Link master reference design optimized for quick prototyping. This design uses the Technologie Management Gruppe (TMG TE) IO-Link master stack for the MAX14819A IO-Link master transceiver and is both an evaluation model for an IO-Link master as well as an IO-Link sensor/actuator development and test system. Two IO-Link ports allow for simultaneous testing of up to two different sensors or actuators.

In this design, an STM32 low power microcontroller interfaces between the MAX14819A and the control board. The MAX14819A is a dual-channel IO-Link master transceiver with integrated framers and L+ supply controllers. Integrated L+ controllers are used to supply power to connected IO-Link devices. The MAX14819A integrated IO-Link framer offloads time-critical tasks from the microcontroller, easing prototyping and software requirements.

Peripheral module interface (Pmod) is an open standard written by Digilent, Inc. and is typically used for quick development and prototyping. The MAXREFDES277# with its pmod-compatible and nonstandard IO-Link connectors is optimized for this type of functionality. In lieu of the standard M12 connectors used in IO-Link, the MAXREFDES277# uses two small on-board connectors with L+, L-, and IO-Link connections to maintain a small size board.

The board ships with two M12-to-wire IO-Link cables required to connect IO-Link devices (for example, sensors and/or actuators) to the MAXREFDES277# master board. An AC-to-DC (24 V_{DC}/1 A) power supply, capable of providing the 24 V power to the on-board MAX14819A IO-Link master transceiver and any connected sensors or devices, is also included.

Connecting the MAXREFDES277# to any Analog Devices IO-Link device reference design, with the associated software, allows for easy evaluation.

Design files and sample MicroPython software are available in the design files.

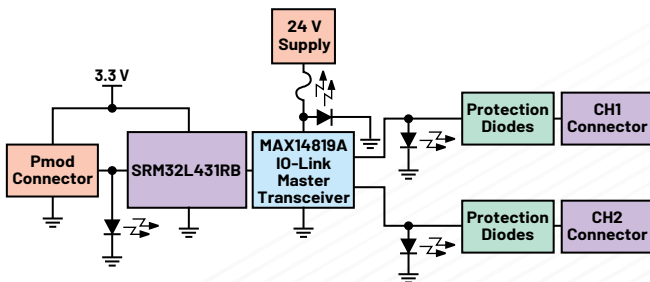

Figure 36. A MAXREFDES277# block diagram.

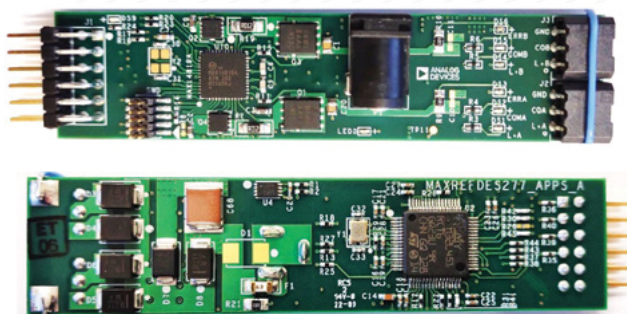

Figure 37. MAXREFDES277# IO-Link to peripheral module device (top and bottom).

IO-Link Master Test Reports

The MAXREFDES145 is a fully compliant IO-Link version 1.1.3 master. See the detailed test report (Figure 38) on our website at [MAXREFDES145 8-Port IO-Link Master Test Report](#).



Name	DUT Check Info
Description	Successful
State info	Successful
Expected result	No
Optional step	No
Comment	
Start of execution	2017-05-04 15:25:40.391
End of execution	2017-05-04 15:25:43.542
Vendor name	Maxim Integrated
Product name	Maxrefdes145#b
Product ID	001
Serial No.	
Hardware Rev.	002
Firmware Rev.	00-005-006-07-001-001-01-005
Description	8 port IO-Link Master.

Figure 38. Details of MAXREFDES145 IO-Link master test report.

The MAXREFDES165# is a fully compliant IO-Link version 1.1.3 master, according to the following test report. It was tested with golden device GD000009. See the detailed test report (Figure 39) for MAXREFDES165# [Four-Channel IO-Link Master Test Report](#).



GD Product Text	IO-Link Golden Device Master Test System
GD Device ID	0x004d7
GD Serial No	GD000009
GD Hardware Rev	0100
GD Firmware Rev	0036

DUT Check Info	
Type	DUT Check Info
Name	DUT Check Info
Description	Successful
State info	Successful
Expected result	No
Optional step	No
Comment	
Start of execution	2018-07-17 13:59:04.955
End of execution	2018-07-17 13:59:04.962
Vendor name	TMG TE GmbH
Product name	IO-Link USB Master interface
Product ID	IOLUSBM
Serial No.	1
Hardware Rev.	1.0
Firmware Rev.	1.0
Description	Test interface fuer USB Master

Figure 39. Details of MAXREFDES165# IO-Link master test report.

Section 6: Improving System Performance

In IO-Link applications, the transceiver acts as the physical layer interface to a microcontroller running the data link layer protocol while supporting up to 24 V digital inputs and outputs. Our transceivers have long supported all IO-Link specifications and feature the lowest power dissipation.

Our first IO-Link device transceiver, the MAX14820, dissipated just under 900 mW with the drivers under full load conditions. The second-generation MAX14826 reduced the already low power dissipation of its predecessor by over 50%, dissipating only 400 mW under full load conditions.

The third-generation MAX14828 single-channel transceiver and the MAX14827A dual-channel transceiver dissipate a remarkably low 70 mW when driving a 100 mA load—achieving more than 80% lower power dissipation than the closest competitive device. For even lower dissipation while driving, the C/Q and DO drivers on our transceivers can also be paralleled.

The most recent IO-Link transceiver, the MAX22513, features a selectable control interface, internal high efficiency DC-to-DC buck regulator, two internal linear regulators, and integrated surge protection for robust communication. The device features low on-resistance drivers (C/Q and DO/DI), selectable driver current limits, and overcurrent protection to reduce power dissipation in small sensor applications.

Heat Dissipation

The results of the following tests highlight the evolution of power dissipation by our device transceivers under different load conditions compared to our competitors.

Test A

In Figure 40, each IC has a 200 mA load on C/Q, meaning dual-channel parts have only one channel loaded. The image (taken with a thermal camera) clearly shows that the MAX14828 and MAX14827A dissipate significantly less power than the competitor's single-channel device.

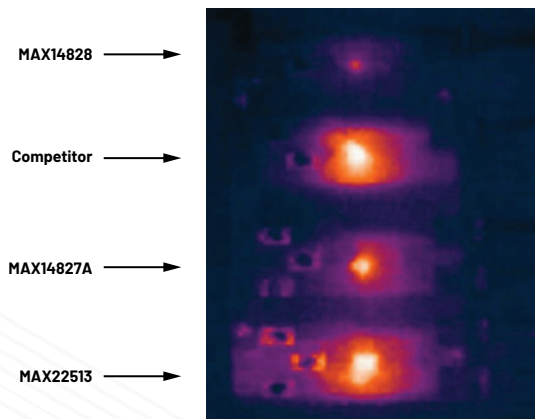

Figure 40. Test A: 200 mA per device.

Test B

In Figure 41, a 200 mA load on each channel means that dual-channel parts (MAX14827A and MAX22513) have twice the load of MAX14828 and the competitor part. The thermal camera clearly shows that the MAX14827A dual-channel device generates less heat or comparable to the competitor's single-channel device.

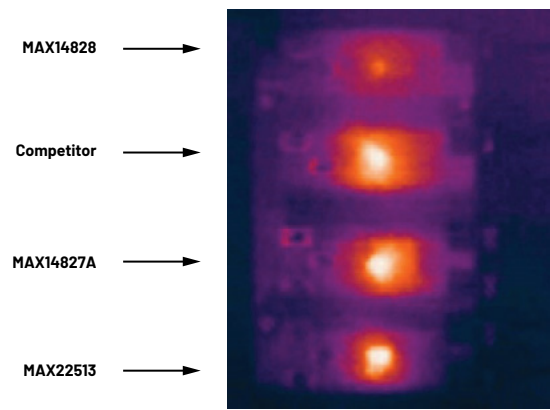

Figure 41. Test B: 200 mA per channel.

Test C

In Figure 42, each IC has a 30 mA load on the 5 V LDO output (from the integrated linear regulator). For MAX14828, MAX14827A, and the competitor's device, the internal LDO regulator must dissipate approximately $(24 \text{ V to } 5 \text{ V}) \times 30 \text{ mA}$ of power. The thermal camera clearly shows that the MAX22513 dissipates significantly less power than the devices without integrated DC-to-DC buck converters. This clearly demonstrates the benefit of the integrated DC-to-DC and its efficiency for sensors with an AFE that need more current from the integrated LDO regulators. The only heat signature for the MAX22513 is in fact an external resistor: the IC runs very cool due to the integrated buck converter.

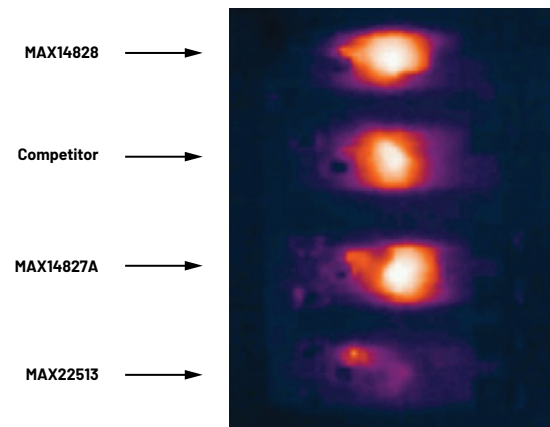

Figure 42. Test C: 30 mA load on a 5 V LDO regulator.

Thermal Performance

Most industrial sensors use either an M8 or a larger M12 cable connector. The type of connector used will impact the enclosure size of the sensor and therefore the amount of heat that can be dissipated. In the following example, we design an IO-Link sensor with a total power dissipation that does not exceed 400 mW if an M8 connector is used, or 600 mW for a sensor using an M12 connector.

Apart from a transducer (pressure/temperature/proximity), an IO-Link industrial sensor will also typically include an analog front end (AFE), a microcontroller, status LEDs, and possibly an output stage to drive an actuator in response to sensor readings. Industrial sensors use a 24 V_{DC} signal voltage, but in a harsh factory

environment, this can be up to 50% higher. While these voltage levels can be safely used to power the output driver stage, the AFE, LEDs, and microcontroller require much lower voltages (3 V to 5 V) for operation. Many IO-Link transceivers provide these voltage levels as linear regulated outputs. However, the decision to use them can have negative implications for overall sensor power consumption (and consequently, heat dissipation). This is especially true if an onboard LDO circuit is used to provide the current for these outputs. For example, consider the following power budget for a small sensor that draws just 15 mA of current through an LDO regulator, powered from a 24 V (typ) DC rail, shown in Figure 43.

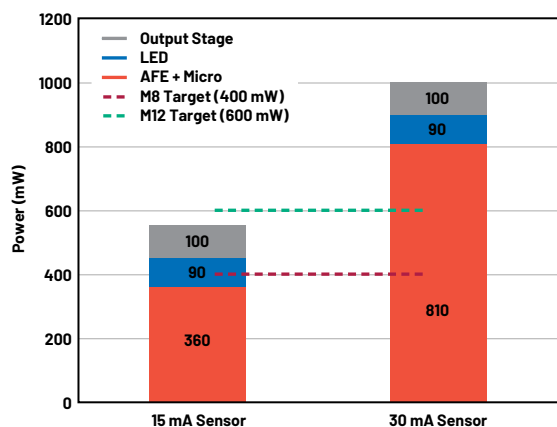

Figure 43. Power budget for a typical LDO regulator-powered IO-Link sensor.

Due to the high losses inside the LDO regulator, this relatively low power sensor has exceeded the ~400 mW power-budget that can be dissipated in a typical M8-connected sensor, and therefore, a larger M12-connected enclosure would be required. Figure 43 also shows that a sensor drawing just 30 mA of current will dissipate 900 mW, exceeding even the target figure for an M12 connector sensor.

Discrete Solution

To reduce overall power consumption (and heat dissipation), the most common solution is to use an external DC-to-DC buck converter to power the AFE and the microcontroller.

For example, a DC-to-DC buck converter supplying a 30 mA sensor with a 3 V output voltage will dissipate just 90 mW. Assuming the converter is 90% efficient (that is, just 9 mW power loss), the overall power consumption is just 90 + 9 = 99 mW. Clearly, power dissipation is reduced by approximately a factor of 9 when compared to using the LDO regulator (900 mW). Including the power consumed by the output stage (100 mW), the overall power reduction would be 1000 mW/199 mW, or approximately a factor of 5, as shown in Figure 44.

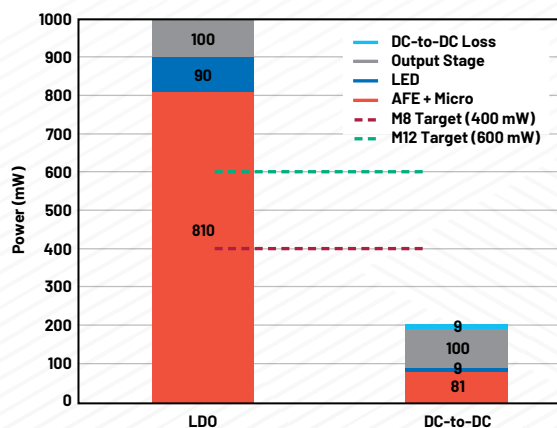

Figure 44. Power reduction using a buck converter vs. an LDO regulator for a 30 mA sensor.

Clearly, the overall power consumption of the sensor (~200 mW) is now well below the target figure for sensors using either type of connector. However, this power reduction is only achieved at the expense of extra external circuitry (that is, the DC-to-DC converter and bulky discrete items such as an inductor, diodes, and capacitors), which increases the overall size of the sensor.

Integrated Solution

The MAX22513 IO-Link transceiver has several advantages when compared to the conventional approach. First, a reverse polarity-protected buck DC-to-DC converter has been fully integrated into the IC package, meaning there is no need for a separate DC-to-DC converter or additional external components. The converter can supply an output current of up to 300 mA (for high current sensor applications) with a 2.5 V to 12 V programmable output voltage. Secondly, unlike most other IO-Link transceivers, the IC also includes a second (auxiliary) IO-Link channel which can be used for DI/DO sensor switching while data is being transferred on the C/Q channel. Despite the inclusion of these extra features, the overall package size is only $2.1 \times 4.1 = 8.6 \text{ mm}^2$ in a wafer-level package (WLP). WLP packaging is visually similar to a BGA package with bumps or balls for soldering to the PCB, but the assembly process is different as explained in [Application Note 1891: Wafer Level Packaging \(WLP\) and Its Applications](#). This represents an almost 50% reduction in component area. Additionally, robust sensor performance in harsh industrial environments is provided by integrated surge protection (up to $\pm 1 \text{ kV}/500 \Omega$) circuitry that negates the need for external TVS diodes.

The MAXREFDES171 is a distance sensor based on the MAX22513. This board has been tested to pass up to $\pm 1 \text{ kV}/500 \Omega$ between the different pairs of pins. External TVS diodes may be used in systems that require higher levels of protection.

Selecting a TVS Diode

This section is a subset of the material covered by [Application Note 6965: How to Select a TVS Diode for Maxim's IO-Link Devices](#).

IO-Link Protection

IO-Link devices (sensor transceiver or master transceiver) have four pins (L+, C/Q, L-, and DI/DO) that need to be protected. When testing for surge protection—for example, these pins need to survive surge pulses between any two pins (referred to as line-to-line testing), with both negative and positive polarity surges. It is important to understand the impact that the Abs Max ratings for these pins have on TVS diode selection. The following examples demonstrate that the higher Abs Max values of ADI IO-Link transceivers enable the use of significantly smaller TVS products, saving board space and cost.

How 65 V (Abs Max) Helps with Protection (vs. 40 V)

Let's consider a test case and see how the Abs Max ratings can affect the final footprint of the circuit. Figure 46 shows the current flow and voltages across the protection scheme when a transient surge pulse is applied to the C/Q pin (referenced to L-) on the MAX14827A. Using the standard 42Ω impedance between the surge pulse ($\pm 1 \text{ kV}$) and the device, the maximum current flow is $\pm 24 \text{ A}$.

Advantages of 65 V Abs Max for Protection

The MAX14827A and MAX14828 have a guaranteed 65 V Abs Max rating, allowing for flexible protection of the IO-Link pins for surge conditions. While competitor parts require bigger, more expensive TVSs, these high Abs Max ADI ICs only require small, low cost TVSs/varistors as follows

- ▶ Smallest TVS diode/standard surge ($\pm 1 \text{ kV}/500 \Omega$): Semtech® $\mu\text{Clamp}^{\circ}603$; PCB area = 1.7 mm^2
- ▶ Lowest cost TVS diode/standard surge ($\pm 1 \text{ kV}/500 \Omega$): varistor; cost is ~50% of regular TVS diode
- ▶ High level surge ($\pm 1 \text{ kV}/24 \text{ A}$): SMAJ33 TVS diode (vs. competitor SMCJ33 TVS diode); $5\times$ smaller PCB area

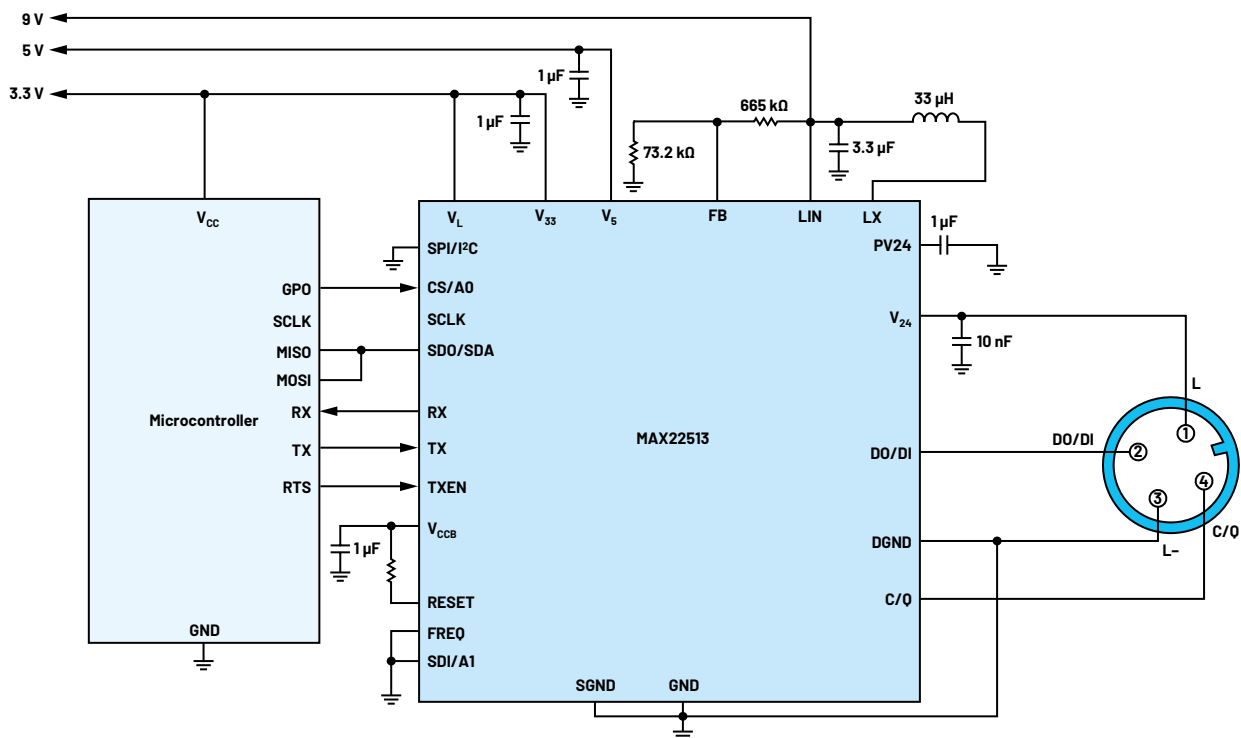

Figure 45. A MAX22513 IO-Link transceiver with integrated DC-to-DC converter.

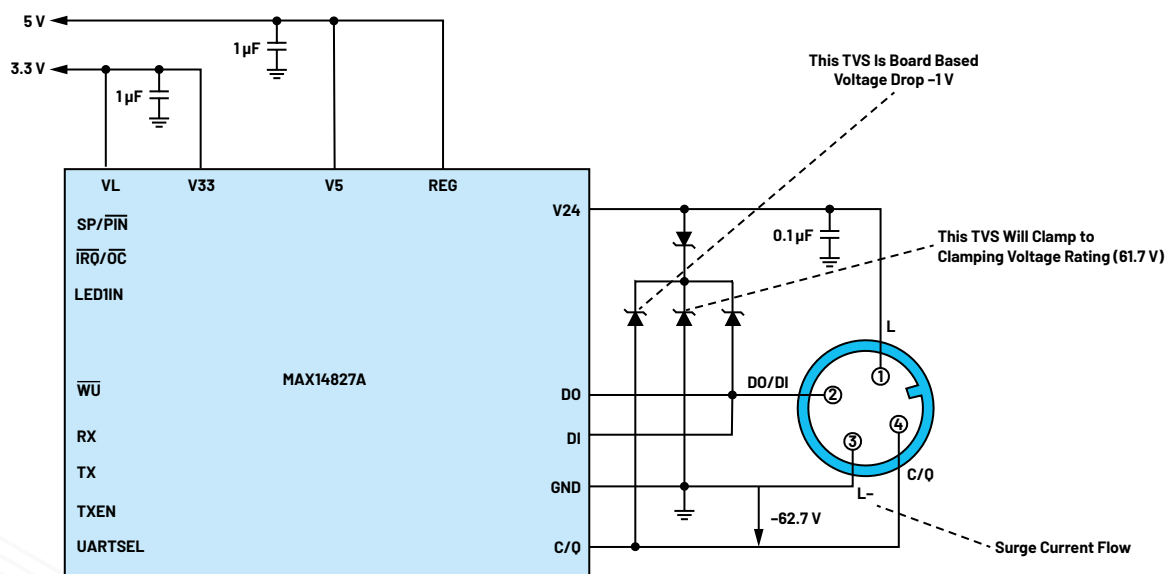

Figure 46. C/O to L+ surge.

Summary

TVS diodes are included on a circuit to protect sensitive devices. During normal operation, the TVS diode must have no significant impact on circuit performance. However, when a high voltage transient occurs, the TVS diode must activate and limit the voltage across the circuit. Large transient events (such as high voltage and current pulses) typically require large diodes for satisfactory protection. We offer the most robust IO-Link transceivers with high voltage tolerances and Abs Max ratings of up to 65 V to provide greater flexibility when selecting TVS protection diodes. Additionally, devices such as the MAX22513 integrate surge protection and remove the need for external TVS devices in many applications.

How Does the IO-Link Signal Slew Rate Affect Emissions from the IO-Link Cable?

Most ADI IO-Link transceiver drivers have a controlled slew rate or even adjustable slew rate for the CQ pin; for example, MAX14819, MAX14827A, and MAX14828 have slew-rate limiting. MAX22513 has selectable slew rate.

IO-Link cables aren't shielded and the signal level is quite high (24 V p-p). So the cable can act as an antenna. To reduce emissions from the cable it's important to limit the maximum frequency available on the cable to the minimum necessary.

The rise and fall-time of the IO-Link as specified for MAX22513 are specified as follows in Table 4.

Table 4. Rise and Fall Time of MAX22513

Driver Rise Time	t_{RISE}	Push-pull or PNP mode, $V_{2A(max)} = 30\text{ V}$	0.1, 0.2, 0.325	μs
			0.40	
			1.22	
			4.7	
Driver Fall Time	t_{FALL}	Push-pull or NPN mode, $V_{2A(max)} = 30\text{ V}$	0.2, 0.34, 0.475	μs
			0.66	
			1.64	
			7.1	

While the steepest rise and fall times (typ 0.2 μs fall-time/typ 0.34 μs rise-time) have strong transmit frequency components up to 1.8 MHz, Max-Frequency = 1/T, while $T = t_{RISE} + t_{FALL}$. This also means the frequency content of the signal on the cable is 1.8 MHz. However, the IO-Link signaling fundamental frequency for the highest IO-Link data rate of COM3 = 230.4 kbps is 115.2 kHz.

To reduce emissions from the cable, it's better to use the slowest rise- and fall-times that still allow communication. Therefore it is recommended to reduce the slew rate when the COM rate is lower.

$t_{RISE} + t_{FALL} = 0.2\ \mu\text{s} + 0.34\ \mu\text{s}$ result in a maximum frequency of about 1.8 MHz.

$t_{RISE} + t_{FALL} = 0.4\ \mu\text{s} + 0.66\ \mu\text{s}$ result in a maximum frequency of about 934 kHz.

$t_{RISE} + t_{FALL} = 1.22\ \mu\text{s} + 1.64\ \mu\text{s}$ result in a maximum frequency of about 349 kHz.

$t_{RISE} + t_{FALL} = 4.7\ \mu\text{s} + 7.1\ \mu\text{s}$ result in a maximum frequency of about 84.74 kHz.

Electromagnetic Compatibility (EMC) Requirements

Industrial environments are harsh and system designers must meet minimum EMC requirements to ensure IO-Link devices can survive some common transients. We start by designing robust IO-Link ICs which typically meet these levels:

- ▶ ESD: $\pm 8\text{ kV}$ for air discharge
- ▶ ESD: $\pm 4\text{ kV}$ for contact discharge (based on the IEC 61000-4-2 standard).

Note: The IEC 61000-4-2 standard covers ESD testing and performance of finished equipment, but does not specifically refer to integrated circuits.

Table 5. IO-Link EMC Test Levels

Phenomena	Test Level	Performance Criterion	Constraints
Electrostatic discharges (ESD) IEC 61000-4-2	Air discharge: $\pm 8\text{ kV}$ Contact discharge: $\pm 4\text{ kV}$	B	See G.1.4. a)
Radio-frequency electromagnetic field Amplitude modulated IEC 61000-4-3	80 MHz to 1000 MHz 10 V/m	A	See G.1.4. a) and G.1.4. b)
	1400 MHz to 2000 MHz 3 V/m		
	2000 MHz to 2700 MHz 1 V/m		
Fast transients (burst) IEC 61000-4-4	$\pm 1\text{ kV}$	A	5 kHz only; the number of M-sequencers in Table G.1 shall be increased by a factor of 20 due to the burst/cycle ratio 15 ms/300 ms; see G.1.4,c)
	$\pm 2\text{ kV}$	B	
Surge IEC 61000-4-5	Not required for an SDCI link (SDCI link is limited to 20 m)		
Radio frequency common mode IEC 61000-4-6	0.15 MHz to 80 MHz 10 V EMF	A	See G.1.4. b) and G.1.4. d)
Voltage dips and interruptions IEC 61000-4-11	Not required for an SDCI link		

EMC Test Levels

Table 5 shows the various system-level EMC test levels from Table G.2 of the IO-Link Interface and System Specification.

Physical Layer: EMC Requirements Standardized

Note that the IEC 61000-4-2 standard covers ESD testing and performance of finished equipment, but does not specifically refer to integrated circuits. Typically, our transceivers can withstand around 1.5 kV ESD transients on their own (based on the military standard used in the reliability reports) but will generally need external TVS diodes for added protection. However, we have reduced the size and requirements of these external diodes and reduced the BOM to save space and external component cost. Industrial environments are typically harsh requiring additional protection for circuits!

The IO-Link specification requires for equipment to be appropriately protected for robust operation:

- ▶ ESD: $\pm 8\text{ kV}$ for air discharge
- ▶ ESD: $\pm 4\text{ kV}$ for contact discharge (based on the IEC 61000-4-2 standard)
- ▶ Surge: Not required when the cable length is limited to 20 m; otherwise, protection levels range from $\pm 500\text{ V}$ to $\pm 2\text{ kV}$
- ▶ Burst: $\pm 1\text{ kV}$ or $\pm 2\text{ kV}$

While transceivers are increasingly robust, external protection is necessary for:

- ▶ ESD protection for the end product
- ▶ Surge and burst protection (TVS diodes)
- ▶ Optimized layout

Immunity Testing

Figures 47 and 48 demonstrate the EFT, surge, and ESD testing of the MAX14819A in the MAXREFDES145 8-port master or a device like the MAX22513 in the MAXREFDES171 sensor. The setup in Figure 47 is only for surge testing. Board-level transient immunity standards include:

- ▶ IEC 61000-4-2 Electrostatic Discharge (ESD)
- ▶ IEC 61000-4-4 Electrical Fast Transient/Burst (EFT)
- ▶ IEC 61000-4-5 Surge Immunity

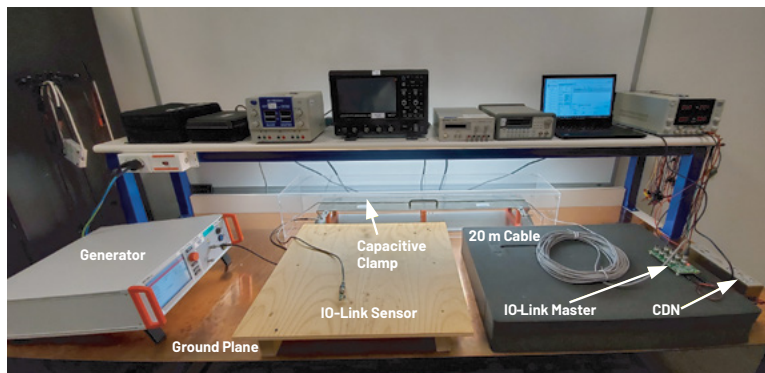

Figure 47. EFT burst and surge testing bench.



Figure 48. ESD testing of MAX14819A.

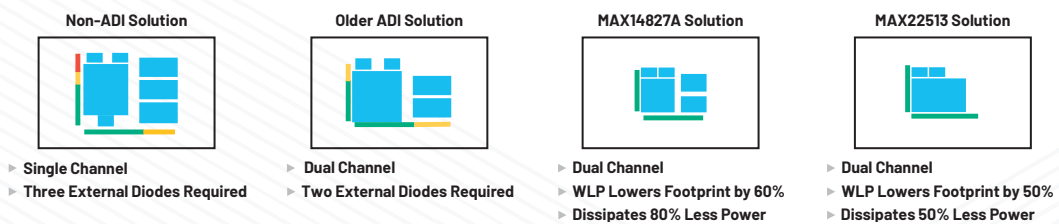

Figure 49. IO-Link transceiver solution comparison.

Section 7: IO-Link Solutions

Why Choose ADI IO-Link Transceivers?

We joined the IO-Link consortium in 2009. We have a proven track record of long-term dedication and commitment to the industrial market and to our customers by having the industry's most complete IO-Link and binary sensor portfolios. These include the [MAX14828](#), [MAX14827A](#), and [MAX22513](#) device transceivers and the [MAX14824](#) and [MAX14819A](#) master transceivers. Note that IO-Link transceivers can also be used in binary sensor applications.

We have developed a complete ecosystem to make design-in fast and easy. The evaluation kits for all our transceivers include software (for configuration and reading/writing to the transceiver). Our IO-Link reference designs include both sensors and masters. Our dedicated team of designers, product definers, and applications engineers are readily available to provide customer support.

Our solutions are small and only getting smaller! Our IO-Link transceivers (Figure 49) are currently available in compact TQFN and WLP packages. The latest transceiver, the [MAX22513](#), is offered in a WLP package and reduces the solution footprint by up to 50% compared to competitor parts. As our transceivers increase in robustness, less external protection is required. With higher absolute maximum ratings, external protection components such as external protective diodes, can be smaller. Our transceivers include integrated 3.3 V and 5 V LDO regulators that can power external circuitry, reducing the need for external LDO regulators and keeping the overall solution small. Additionally, the [MAX22513](#) has an integrated DC-to-DC converter to reduce power dissipation for higher current sensors.

Product Selector Guide

Our long and committed history with IO-Link technology has resulted in the development of multigeneration transceivers on both the master and device side that focus on low power dissipation, small solution size, and robust communications (Table 6). With a full ecosystem of IO-Link device and master reference designs and evaluation kits, we are focused on providing quick evaluation of IO-Link technology.

100 mA Tiny Binary Sensor Drivers: [MAX14838](#)/[MAX14839](#)

The [MAX14838](#)/[MAX14839](#) 24 V/100 mA drivers are optimized for use in industrial sensors. These devices integrate the high voltage (24 V) circuitry commonly found in industrial sensors, including a configurable PNP/NPN/push-pull driver and an integrated linear regulator that meets common sensor power requirements.

- ▶ Pin-Selectable High-Side (PNP), Low-Side (NPN), or Push-Pull Driver
- ▶ On-Chip 5 V Linear Regulator ([MAX14838](#))/3.3 V Linear Regulator ([MAX14839](#)) (Figure 50)
- ▶ Dual Integrated 2 mA LED Drivers
- ▶ Integrated Protection Provides Robust Sensor Solutions
 - Reverse-Polarity Protection on DO, V_{CC} , and GND
 - 4.75 V to 34 V Supply Range ([MAX14839](#))
 - V_{CC} Hot-Plug Protection
 - Thermal Shutdown Protection
 - ± 8 kV IEC 61000-4-2 Air Gap ESD Protection
 - -40°C to $+105^{\circ}\text{C}$ Temperature Range
 - ± 1 kV/500 Ω Surge Protection

Table 6. IO-Link Transceivers

Part Number	Description	Interface
IO-Link Master Transceivers		
MAX14819 / MAX14819A	IO-Link	Low power dual-channel IO-Link master transceiver + supply controllers + UART/Framer + DI
MAX14824	IO-Link	Single-channel IO-Link transceiver
IO-Link Device Transceivers		
MAX14828	IO-Link	Tiny low power single-channel IO-Link device transceiver
MAX14827A	IO-Link	Tiny low power dual IO-Link device transceiver
MAX14829	IO-Link	Pin-driven, low power dual IO-Link device transceiver
MAX22513	IO-Link	Surge-protected dual-channel IO-Link device transceiver with DC-to-DC converter
MAX22514	IO-Link	Surge-protected single-channel IO-Link device/master transceiver with DC-to-DC converter
MAX22515	IO-Link	Pin or I ² C mode, dual-channel IO-Link device transceiver with surge protection
MAX22516*	IO-Link	IO-Link device data link controller transceiver
IO-Link Sensor Drivers		
MAX14838	Binary	24 V/100 mA pin-configurable industrial sensor output driver + protection
MAX14839	Binary	24 V/100 mA pin-configurable industrial sensor output driver + protection, 5 V LDO
MAX14832	Binary	24 V/100 mA one-time-programmable (OTP) industrial sensor output driver + protection
MAX14836	Binary	24 V dual-output sensor transceiver
MAX22520	Binary	24 V one-time-programmable (OTP) industrial sensor with analog signal sensing circuitry

* Scheduled for release in spring 2023.

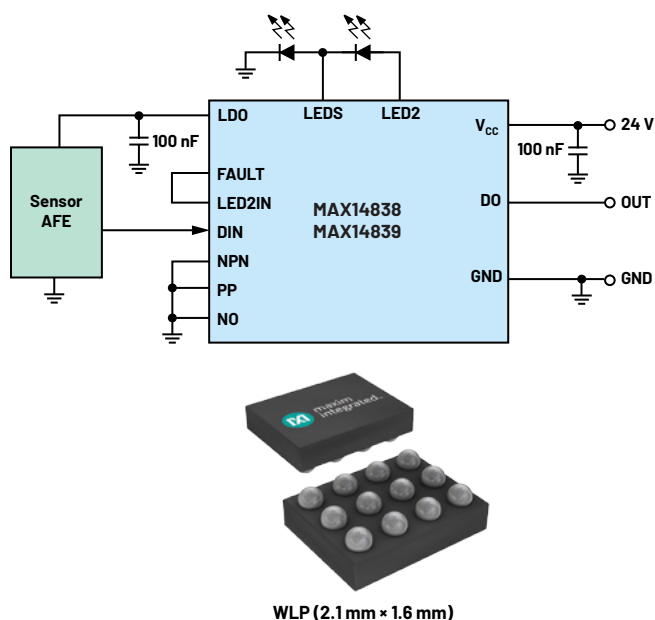

Figure 50. A MAX14838/MAX14839 binary sensor driver.

OTP Programmable Sensor Interface: MAX22520

The MAX22520 (Figure 51) industrial sensor output driver is configurable using ADI's 1-Wire protocol and OTP interface to permanently operate in either normally open or normally closed configuration in PNP (high-side), NPN (low-side), or push-pull modes. The maximum load current is one-time programmable (OTP) to either 100 mA or 200 mA.

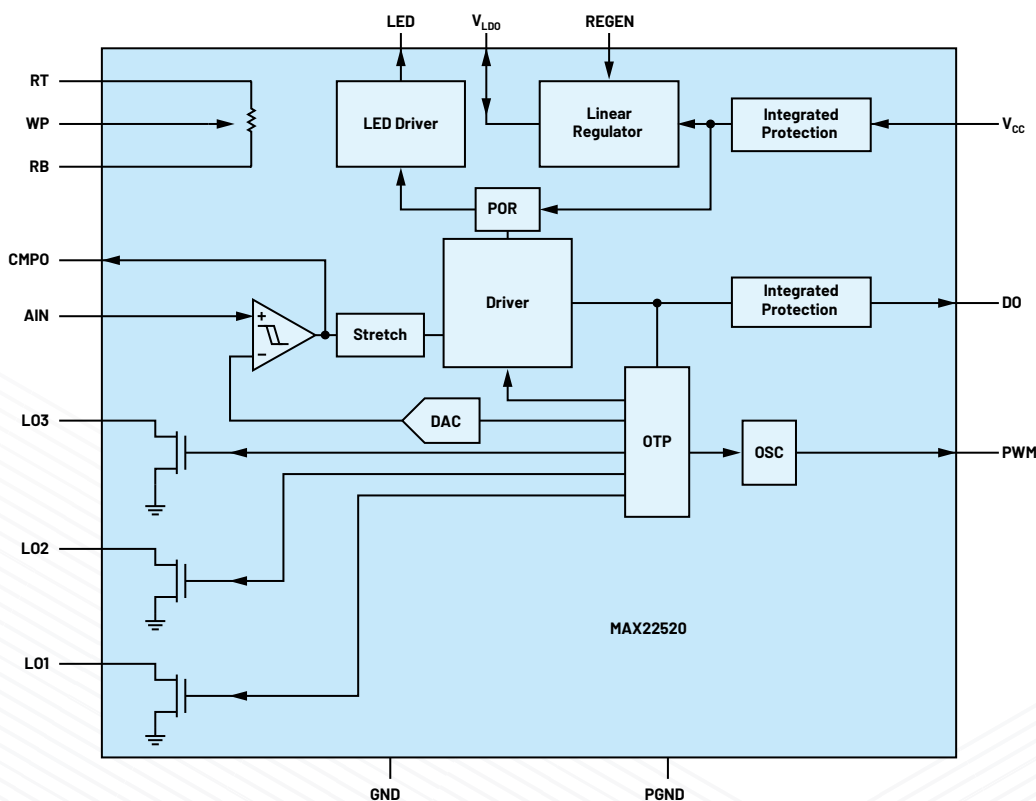

Figure 51. A MAX22520 OTP industrial sensor output driver.

The device also features an OTP programmable comparator, PWM oscillator, and digital potentiometer. These blocks support calibration of sensors via signal generation and signal conditioning of analog sensing circuitry. An integrated LED driver provides visual feedback of the binary sensor's logic state.

- ▶ High Configurability
 - 4.75 V/8 V (min) to 36 V Supply Voltage
 - Programmable Driver Configuration: PNP/NPN/Push-Pull
 - Programmable Driver Current Limit: 100 mA or 200 mA
 - Linear Regulator with Programmable Output: 3.3 V or 5 V
 - Comparator with Programmable Threshold
 - Digital Potentiometer with Programmable 6-Bit Tap
 - Oscillator with Programmable PWM Duty Cycle
- ▶ Robust Design
 - Fast Demagnetization of Inductive Loads
 - Reverse Polarity Protection on DO, V_{CC}, GND
 - Short-Circuit Protection on DO
 - Overtemperature Protection
 - ±8 kV IEC61000-4-2 Air-Gap ESD Protection
 - ±6 kV IEC61000-4-2 Contact Discharge ESD Protection
 - ±1 kV/500 Ω IEC61000-4-5 Surge Protection
 - -40°C to +105°C Operating Temperature Range
- ▶ Small Form Factor for Compact Designs
 - Ultrasmall (2 mm × 2.5 mm) 20-Ball WLP
 - Integrated LED Driver for Visual Feedback

Dual 250 mA IO-Link Transceiver: MAX14827A

The MAX14827A integrates the high voltage functions commonly found in industrial sensors, including drivers and regulators. The MAX14827A features two ultra low power drivers with active reverse-polarity protection (Figure 52). Operation is specified for normal 24 V supply voltages up to 60 V. Transient protection is simplified due to high voltage tolerance allowing the use of micro TVS.

The device features a flexible control interface. Pin control logic inputs allow for operation with switching sensors that do not use a microcontroller. For sensors that use a microcontroller, an SPI interface is available with extensive diagnostics. For IO-Link operation, a three-wire UART interface is provided, allowing interfacing to the microcontroller UART. Finally, a multiplexed UART/SPI option allows using one serial microcontroller interface for shared SPI and UART interfaces.

The device includes on-board 3.3 V and 5 V linear regulators for low noise analog/logic supply rails. The MAX14827A is available in a 24-lead TQFN package and a 25-lead WLP and is specified over the extended -40°C to +125°C temperature range.

- ▶ Lowest Power and Smallest IO-Link Transceiver
 - WLP Package (2.5 mm × 2.5 mm)
 - TQFN Package (4 mm × 4 mm)
- ▶ Low 2.3 Ω (typ) R_{ON} Reduces Power Consumption
- ▶ Robust Protection: 65 V Absolute Maximum for Smaller External Protection and Reverse-Polarity/Short-Circuit Protection

A single-channel version, the MAX14828, is also available and this device has an even lower R_{ON} of 1.2 Ω.

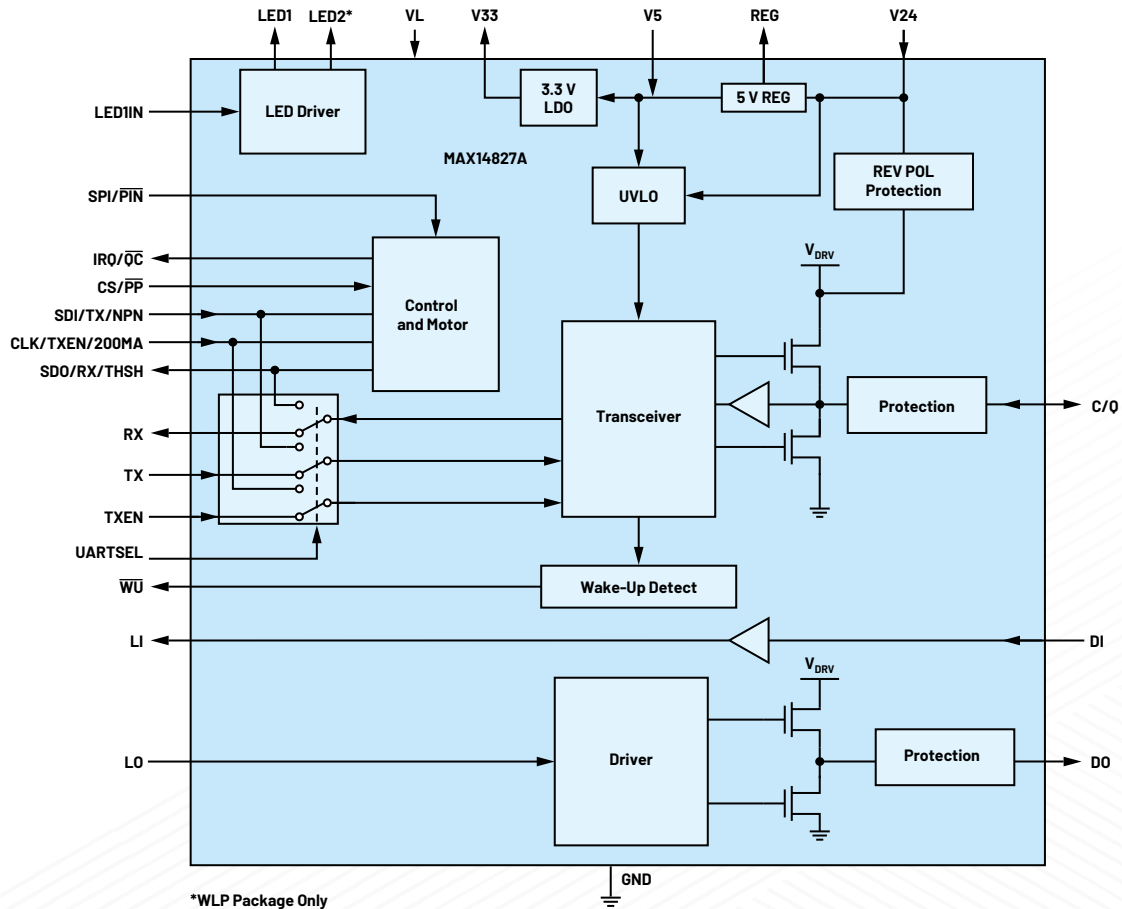

Figure 52. A MAX14827A dual-channel IO-Link transceiver.

Pin-Control, Low Power, Dual-Channel IO-Link Device Transceiver: MAX14829

The MAX14829 dual-channel low power IO-Link device (Figure 53) features a pin-based interface for control, configuration, and monitoring. Pin-control logic inputs allow for operation with switching sensors that do not use a microcontroller. For IO-Link operation, a three-wire UART interface is provided, allowing interfacing to the UART. The MAX14829 has selectable driver current from 100 mA to 330 mA.

- ▶ Low Power Dissipation Reduces the Thermal Footprint for Small Sensors
- ▶ 2.3 Ω /2.7 Ω (typ) Driver On-Resistance
- ▶ 70 mW (typ) Power Dissipation at 100 mA When Both C/Q and DO Drivers Are Driving
- ▶ High Configurability and Integration Reduce SKUs
- ▶ Auxiliary 24 V Digital Output (DO) and Input (DI)
- ▶ Selectable Driver Integrated Protection Enables Robust Communication
- ▶ 65 V Absolute Maximum Ratings on Interface and Supply Pins Allows for Flexible TVS Protection
- ▶ Reverse Polarity Protection of All Sensor Interface Inputs/Outputs

Surge-Protected Dual-Channel IO-Link Device Transceiver with DC-to-DC Converter: MAX22513

The MAX22513 dual-channel low power IO-Link device transceiver (Figure 54) features a selectable control interface, internal high efficiency DC-to-DC buck regulator, two internal linear regulators, and integrated surge protection for robust communication. The device features low on-resistance drivers (C/Q and DO/DI), selectable driver current limits, and overcurrent protection to reduce power dissipation in small sensor applications.

The MAX22513 features extensive integrated protection to ensure robust communication in harsh industrial environments. All four IO pins (V24, C/Q, DO/DI, and GND), are reverse-voltage-protected, short-circuit-protected, and feature an integrated ± 1 kV/500 Ω surge protection.

Surge Testing

The MAXREFDES171 (with the MAX22513) module was tested to withstand up to ± 1 kV of 1.2/50 μ s IEC 61000-4-5 surge with a total source impedance of 500 Ω . Surge testing was performed using the MAXREFDES145 IO-Link master, and 10 surge pulses were applied for each test as shown in Table 7. The MAXREFDES171 was not damaged by the tests.

- ▶ L+ to GND: Communicating with the master, the module continued to execute code and transfer data, and the MAX22513 registers were not corrupted.
- ▶ C/Q to GND: Communicating with the master, the module continued to execute code and transfer data, and the MAX22513 registers were not corrupted.
- ▶ L+ to C/Q: Communicating with the master, the module continued to execute code and transfer data, and the MAX22513 registers were not corrupted.

Table 7. Surge Testing Results

Test Condition	L+ to GND	C/Q+ to GND	L+ to C/Q
+1 kV	Pass	Pass+	Pass+
-1 kV	Pass	Pass+	Pass+

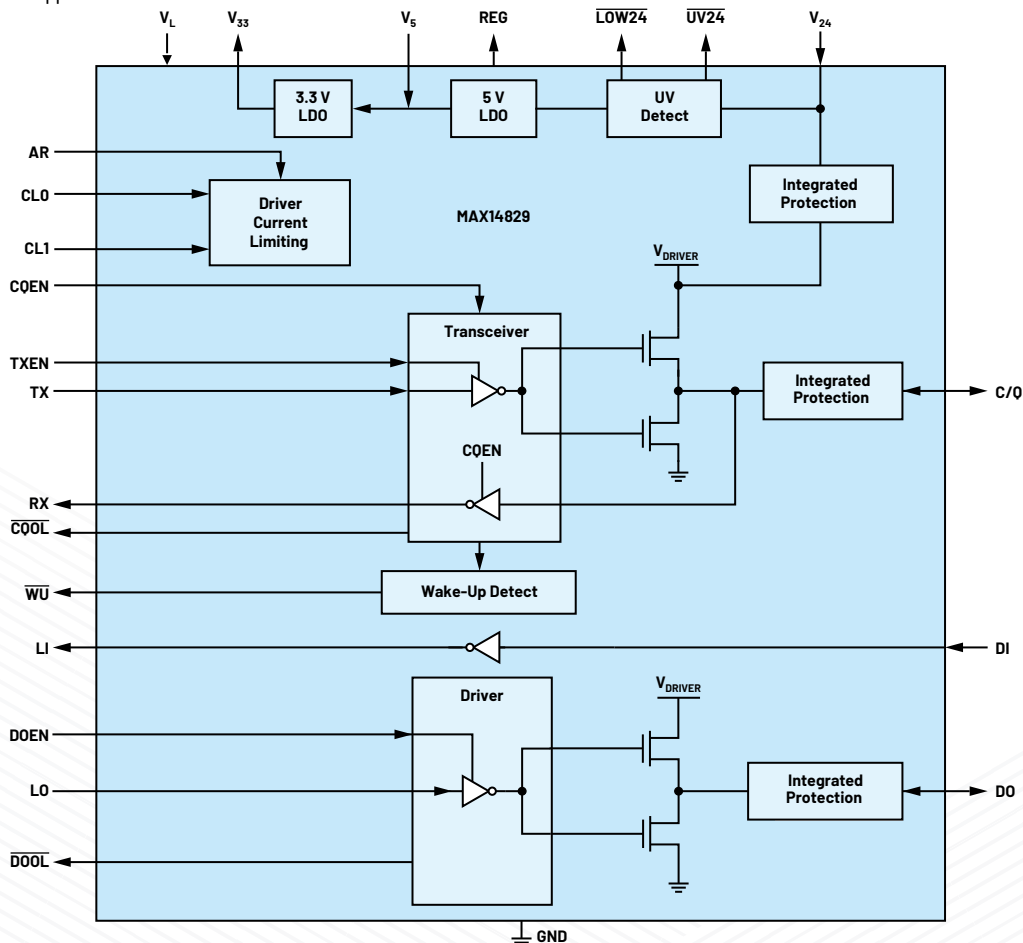

Figure 53. A MAX14829 pin-control, dual-channel IO-Link transceiver.

IO-Link Transceiver with Integrated Protection: MAX22515

The MAX22515 low power industrial transceiver (Figure 55) operates as either an IO-Link device or a non-IO-Link sensor transceiver in industrial applications. The MAX22515 features a selectable control interface (pin-mode or I²C), two integrated linear regulators, and integrated surge protection for robust communication. The transceiver includes one C/Q input-output channel and one digital input (DI) channel.

The device features a flexible control interface. Pin-control logic inputs allow for operation with switching sensors that do not use a microcontroller. For sensors that use a microcontroller, an I²C interface is available to provide extensive

configuration and diagnostics. Additionally, an integrated oscillator simplifies the clock generation for IO-Link devices.

The MAX22515 features extensive integrated protection to ensure robust communication in harsh industrial environments. All IO-Link line interface pins (V₂₄, C/Q, DI, and GND) are reverse-voltage-protected, short-circuit-protected, hot-plug-protected, and feature integrated ±1.2 kV/500 Ω surge protection.

The MAX22515 is available in a tiny WLP package (2.5 mm × 2.0 mm) or a 24-lead TQFN-EP package (4 mm × 4 mm) and operates over the -40°C to +125°C temperature range.

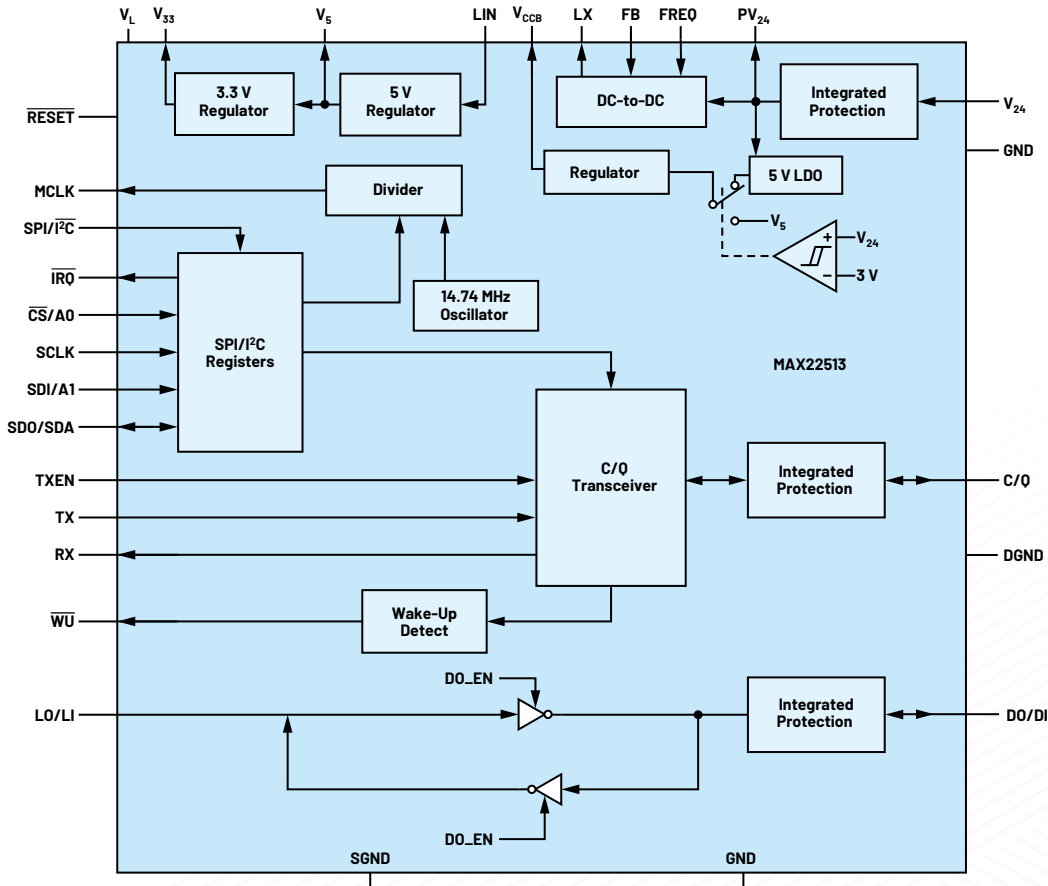

Figure 54. A MAX22513 dual-channel IO-Link transceiver with DC-to-DC converter.

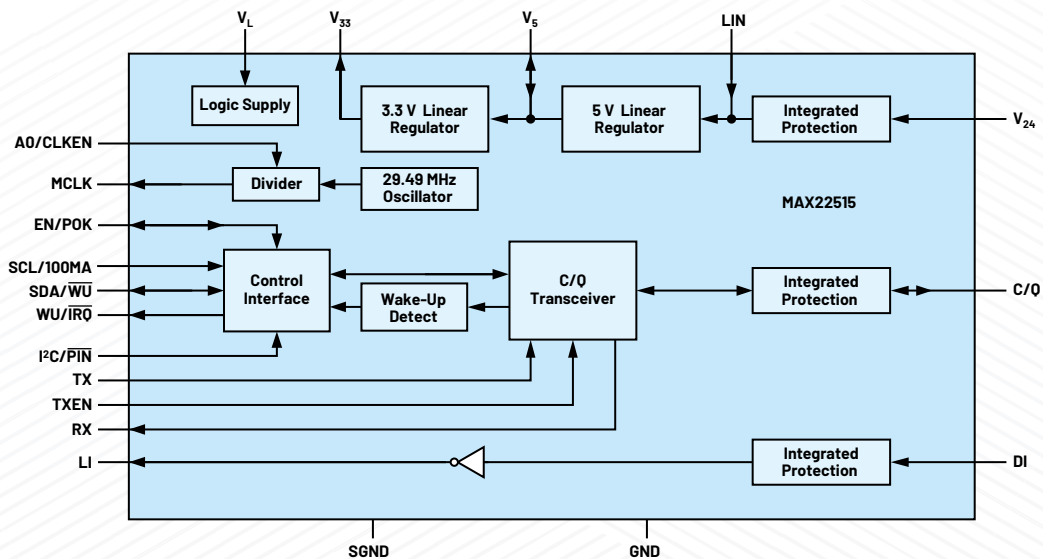

Figure 55. A MAX22515 block diagram.

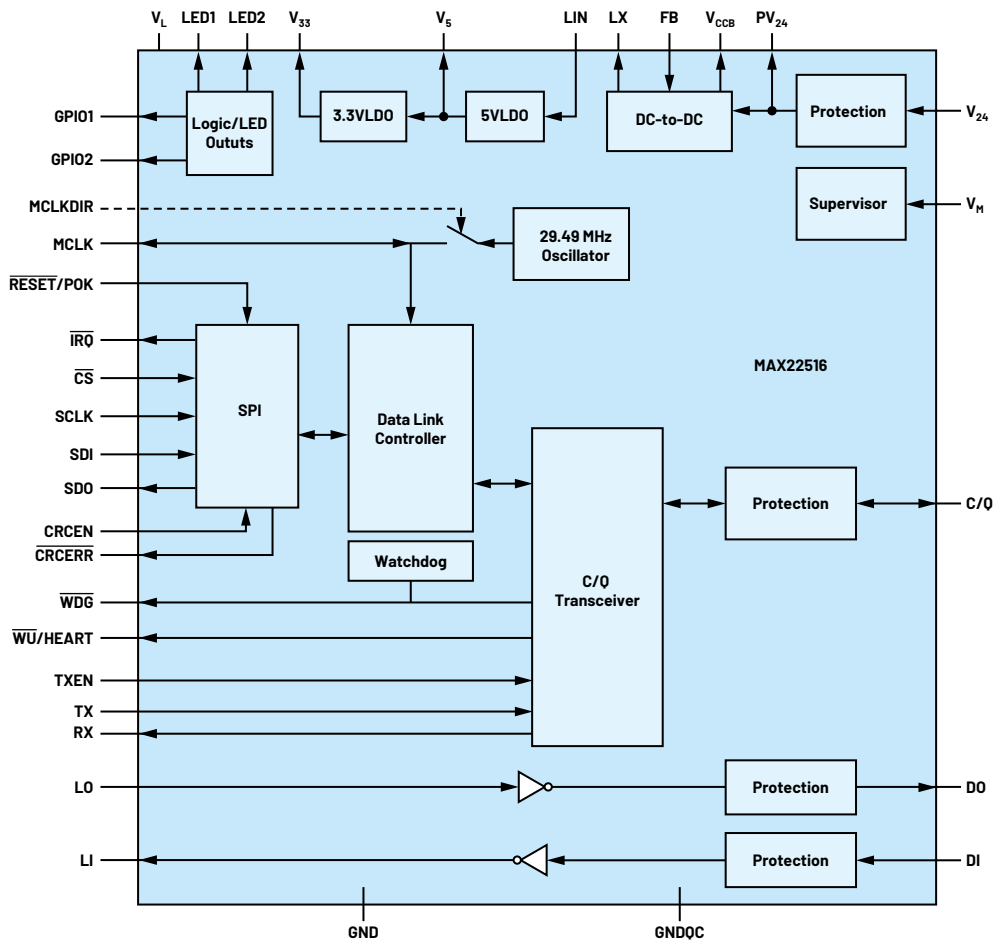

Figure 56. A MAX22516 IO-Link data link controller with transceiver and integrated DC-to-DC controller.

MAX22516 (Coming Spring 2023)

The MAX22516 IO-Link data link controller (Figure 56) integrates all 24 V functionality commonly found in IO-Link devices, including the 24 V C/O transceiver, an auxiliary digital input and output, an integrated DC-to-DC converter, and 5 V and 3.3 V linear regulators together with a full-feature IO-Link data link controller.

Once configured, the integrated IO-Link transceiver is operated by the data link controller in the MAX22516, requiring no microcontroller intervention during normal operation. The IO-Link transceiver can optionally be directly controlled using the TX, TXEN, RX UART interface. The data link controller supports and includes receive and transmit buffers for all defined IO-link M-sequence types: Type 0, Type 1.1, Type 2.2, and up to Type 2.V. Buffers for maximum size process data, ISDU, event, and page data reduce the need for time-critical microcontroller intervention, operating at COM1, COM2, and COM3 data rates while allowing the microcontroller to focus on the application layer processes.

The MAX22516 features extensive integrated protection to ensure robust communication in harsh industrial environments. All IO-Link line interface pins (V24, C/O, DI, and GND) are reverse-voltage protected, short-circuit protected, and hot-plug protected, and feature integrated ± 1.2 kV/500 Ω surge protection.

The MAX22516 is available in a small 42-ball WLP package (3.5 mm \times 3.1 mm) or a 40-lead TQFN-EP package (5 mm \times 5 mm) and operates over the -40°C to $+125^{\circ}\text{C}$ temperature range.

Dual-Channel IO-Link Master Transceiver: MAX14819A

The MAX14819A low-power, dual-channel, IO-Link master transceiver with sensor/actuator power-supply controllers (Figure 57) is fully compliant with the latest IO-Link and binary input standards and test specifications, IEC 61131-2, IEC 61131-9 SDCI, and IO-Link 1.1.3. This master transceiver also includes two auxiliary Type 1/Type 3 digital input (DI) channels. The MAX14819A is configurable to operate either with external UARTs or using the integrated framers on the IC. To ease selection of a microcontroller, the master transceiver features frame handlers with UARTs and FIFOs. These are designed to simplify time-critical control of all IO-Link M-sequence frame types. The MAX14819A also features autonomous cycle timers, reducing the need for accurate controller timing. Integrated communication sequencers also simplify wake-up management.

The MAX14819A integrates two low power sensor supply controllers with advanced current limiting, reverse-current blocking on L+, and reverse-polarity protection capability to enable low-power robust solutions.

The MAX14819A is available in a 48-lead (7 mm \times 7 mm) TQFN package and is specified over the extended -40°C to $+125^{\circ}\text{C}$ temperature range.

- ▶ Low Power Architecture
 - 1 Ω (typ) Driver On-Resistance
 - 1.9 mA (typ) Total Supply Current for Two Channels
- ▶ Integrated Protection Enables Robust Systems

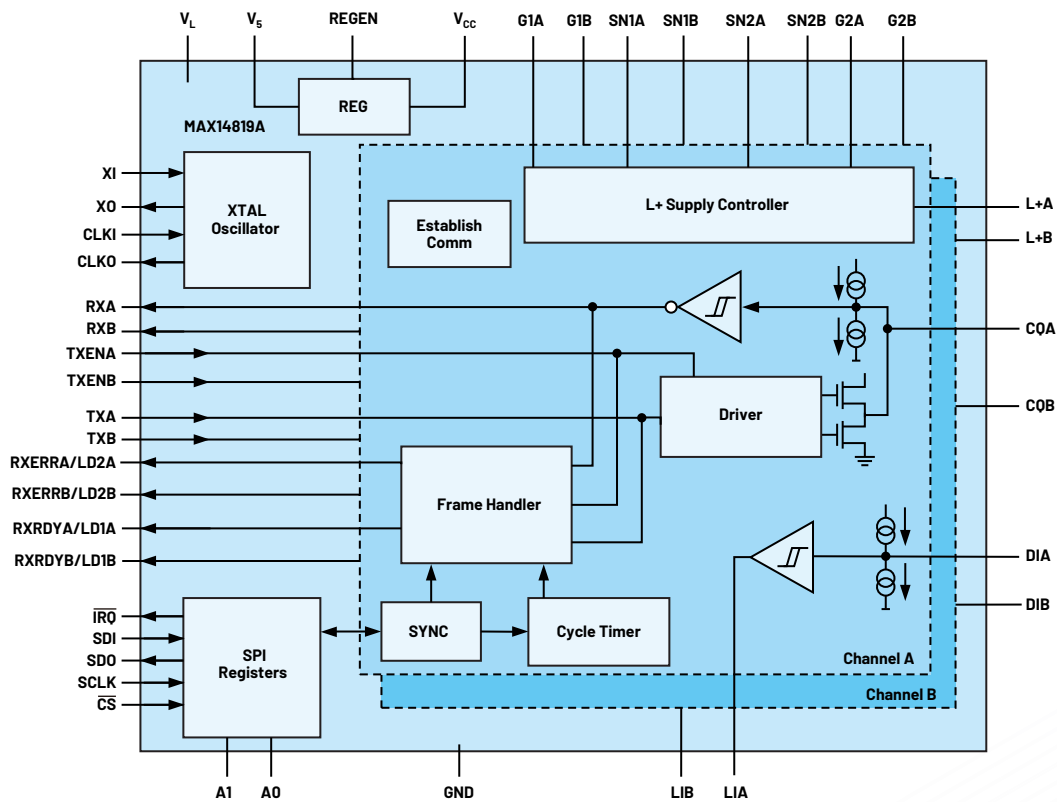

Figure 57. A MAX14819A dual IO-Link master transceiver.

Evaluating an IO-Link Device

The [MAX22513 evaluation kit](#) (EV kit) consists of a MAX22513 evaluation board that is a fully assembled and tested circuit board that evaluates the MAX22513 IO-Link device transceiver. The MAX22513 EV kit (Figure 58) is designed to operate as a standalone board or with an Arduino®-compatible board (not supplied) for easy software evaluation. The EV kit provides the user with an IO-Link-compliant device transceiver with a proven PCB layout. The EV kit is fully assembled and tested with a free GUI to make it easy to use for product evaluation and testing. The EV kit does NOT include an IO-Link device stack.



Figure 58. A MAX22513 evaluation kit.

Evaluating an IO-Link Master

The [MAX14819A evaluation kit](#) (EV kit) consists of the evaluation board and software. The EV kit (Figure 59) is a fully assembled and tested circuit board that evaluates the MAX14819A IO-Link dual-channel master transceiver. The MAX14819A EV kit includes Windows-compatible software that provides a GUI for exercising the features of the device. The EV kit is connected to a PC through a USB A-to-micro B cable. The EV kit does NOT include an IO-Link master stack.

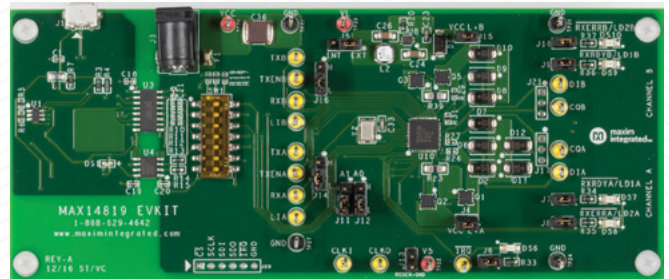

Figure 59. A MAX14819A evaluation kit.

Industrial IO-Link Reference Designs

To help our customers reduce their product development time, we have developed (in collaboration with IO-Link stack software vendors) a range of [IO-Link reference designs](#) (Table 8). Each reference design includes high-performance products in tested circuits.

All reference designs are provided with an IO-Link stack for use while evaluating this design.

ADI Reference Design Use Restrictions and Warnings

Our reference designs have been verified and tested to meet IO-Link specifications while operating in harsh industrial environments, as required by IEC 61000-4-x standards for transient immunity.

Our reference design boards and associated software are designed to evaluate the performance of our IO-Link ICs but are not intended to be deployed as-is into an end-product in a factory automation system, nor should they be used in functional safety and/or safety critical systems.

All reference designs are provided with an IO-Link stack for use while evaluating this design.

Table 8. IO-Link Reference Designs

Reference Design	ADI IO-Link Transceiver	ADI Sensor/IO ICs	Description
IO-Link Master			
MAXREFDES145	MAX14819A	MAX14819A	8-port IO-Link master (TEConcept)
MAXREFDES165	MAX14819A	MAX14819A	4-port IO-Link master (TMG)
MAXREFDES277	MAX14819A	MAX14819A	2-port IO-Link Master, Pmod-compatible form factor (TMG)
IO-Link Sensor			
MAXREFDES37	MAX14821	MAX14821	IO-Link quad servo driver (TMG)
MAXREFDES42	MAX14821	MAX31865	IO-Link RTD temp sensor (IQ2)
MAXREFDES163	MAX14839	MAX14839	Binary industrial magnetic sensor
MAXREFDES164	MAX14828	MAX31875	IO-Link local temp sensor (TMG and TEConcept)
MAXREFDES171	MAX22513	MAX22513	IO-Link distance sensor (TMG)
MAXREFDES173	MAX14827A	MAX31875	IO-Link local temp sensor (IQ2)
MAXREFDES174	MAX22513	MAX22513	IO-Link distance sensor (IQ2)
MAXREFDES176	MAX22515	MAX22190, MAX22192	IO-Link digital input hub (TMG)
MAXREFDES177	MAX22515	MAX22000	Universal analog IO (TMG)
MAXREFDES281*	MAX22516		IO-Link to Pmod-compatible adapter (TMG)
MAXREFDES284*	MAX22516	MAX32660	IO-Link to Pmod-compatible adapter (TEConcept)
IO-Link Actuator			
MAXREFDES278	MAX22514	MAX22200	8-channel solenoid actuator (TMG)

* Scheduled for release in March 2023.

Appendix of Technical Resources

Software Stack Vendors

Typically, IO-Link master and sensor manufacturers require a third party to generate the software stack. We have collaborated with key software vendors to support our IO-Link transceivers for sensor and master designs. Please contact our software partners directly for specific details of their products.

TEConcept

TEConcept GmbH
Wentzingerstraße 21
79106 Freiburg
Germany
Phone: +49 761 214436 40
Email: otto.witte@teconcept.de
Web: teconcept.de



Technologie Management Gruppe
Technologie und Engineering GmbH
Zur Gießerei 10
76227 Karlsruhe
Germany
Phone: +49 721 8280 60
Email: willems@tmgte.de
Web: tmgte.com

IQ² Development

IO-Link Intelligent Components

IQ² Development GmbH & Co. KG
Carl-Benz-Straße 3
72585 Riederich
Germany
Phone: +49 7127 5706100
Fax: +49 7127 5706102
E-Mail: info@iq2-development.de
Web: iq2-development.de



Hefei Onsoon Intelligent Electronics Co., Ltd.
4th floor, Building 3, Yitao Science Park, No. 99, Fushan
Road, Hefei High-Tech Zone, China
Phone: +86 551 6526 1850
Contact: Liu Cong
Email: liucong@onsoon.cn

TMG Technologie und Engineering

Note: The following information is provided by TMG Technologie und Engineering as an example of the types of products and services each software vendor provides. Please contact the software partner for further details.

▶ **TMG Technologie und Engineering - Portfolio**



PROFINET[®] Accredited by PROFIBUS & PROFINET International
IO-Link Accredited by IO-Link Community Competence & Test Center
PROFINET[®] Accredited by PROFIBUS & PROFINET International
EtherCAT[®] Technology Group
EtherNet/IP[™] Member of ODVA

▶ **Consulting**

- Trainings & Workshops
- System and architecture analyses
- Choice of Technology & Components
- Platform & System Concepts

▶ **Services**

- Development
- Expertise
- Interoperability Tests
- Certification support
- Operate demo systems

▶ **Products**

- Communication Stacks
- Engineering Tools
- Test Systems
- Communication Modules
- IO-Link Device Module
- IO-Link Master Modules

Copyright © 2019 TMG Technologie und Engineering GmbH



Technologie Management Gruppe
Technologie und Engineering

1

▶ **IO-Link Device Technology from TMG**





▶ **IO-Link V1.1 Device Stack**

- complete layer 7 functionality, all telegram types
- supports also IO-Link V1.0 compatibility
- easy to port to all microcontrollers (8/16/32)
- works with all IO-Link transceivers
- small footprint

• **IO-Link V1.1.2 Stack Extensions**

- Implements the IO-Link related device application with
 - Parameter Manager, Data storage, Block Parameterization,
 - Device Access Locks, Event Dispatcher,
 - Device Status and Detailed Device Status
 - Parameter Consistency Check, Reset to factory settings
- Production settings (like serial number, calibration and pre parameterization of variants)
- Best practice implementation proved in many customer projects

• **IO-Link Device – Firmware Update**



- Firmware update via IO-Link Bootloader
- IODD based Firmware Packager including encryption
- Supported from IO-Link Device Tool V5.1

Copyright © 2019 TMG Technologie und Engineering GmbH



Technologie Management Gruppe
Technologie und Engineering

2

▶ IO-Link Master Technology from TMG (1)



▶ **IO-Link V1.1 Master Stack**

- supports all telegram types (230kBit/s, 400µs cycle time)
- easy to port to many microcontrollers
- Includes parameter server (data storage)
- Already implemented to V850, Rx, 78K0R, 80C164, PIC32, STM32, R32, ARM9, CORTEX M3/M4/A7 and others
- Support of all master Phys
- Number of ports depends only on µC resources

▶ **IO-Link V1.1 Module and Module In Design Solution**

- STM32F4 Cortex M4
- Maxim Transceiver MAX14819
- HW-Module 4 or 8 ports
- In-Design-Solution: 2, 4 or 8 Ports
 - Schematics & Firmware
- SPI communication to host controller
- Firmware update via SPI
- Host library, portable, ANSI-C
- Pre certified with TMG test report





Copyright © 2019 TMG Technologie und Engineering GmbH



Technologie Management Gruppe
Technologie und Engineering

3

▶ IO-Link Master Technology from TMG (2)



▶ **Smart Interface Protocol : SMI-TCP**

- Fieldbus independent protocol for
 - IO-Link Device Tool V5.1 – Professional Edition
 - IO-Link Master Test
 - Industrie 4.0 and IOT applications, 2nd Channel
- Properties
 - based on TCP/IP
 - Standard Master Interface (SMI, IO-Link Spec V1.1.3)
 - Multiple connections
 - Support of modular systems
 - Support of sub networks

▶ **Fieldbus Integration**

- Based on Standard Master Interface (SMI)
- PROFINET (Integration specification ED 2)
- EtherNet/IP
- EtherCAT
- Modbus TCP
- PROFIBUS
- and others ...



Copyright © 2019 TMG Technologie und Engineering GmbH



Technologie Management Gruppe
Technologie und Engineering

4

▶ TMG IO-Link Device Tool V5.1 – Professional Edition

- Executable as independently Windows application
- Integration into PLC engineering tools like STEP 7 or TIA Portal via TCI (Tool Calling Interface)
- Master manufacturer and fieldbus wide operation
 - According to the requirements of the AIDA group
- IO-Link master / port configuration
 - Operation of IO-Link master without PLC possible
 - Take over configuration from engineering tool (TCI)
 - Take over configuration from IO-Link master (PLC)
 - Data Storage content transfer and storage
- IODD Interpreter: Open to all IO-Link Devices worldwide
- Open IO Device GUI: Graphical User Interfaces for IO-Link Devices
- IODD Viewer
- IODD Finder: Easy import of IODDs from the Internet Database
- Firmware Update Profile
- IO-Link Safety (parameterization and commissioning)



Revision: 4.0.23
Build: 2016-8-16
Copyright © 2016 TMG Technologie und Engineering GmbH

supports also



MAXREFDES165#

Copyright © 2019 TMG Technologie und Engineering GmbH

Technologie Management Gruppe
Technologie und Engineering

5

▶ IO-Link Device Tool V5.1 – PE : Tool Calling Interface (TCI)

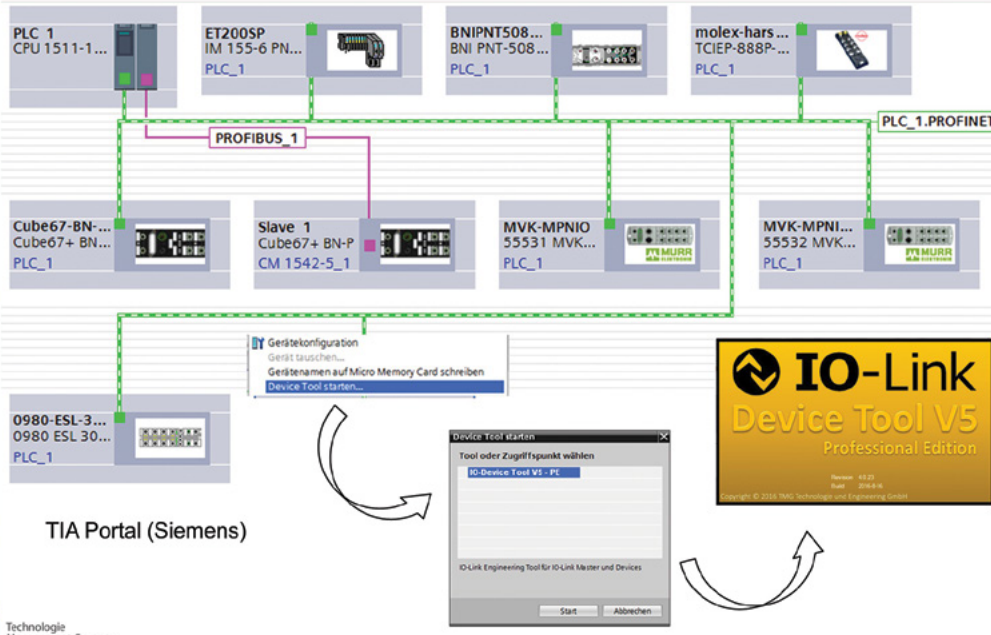

TIA Portal (Siemens)



Revision: 4.0.23
Build: 2016-8-16
Copyright © 2016 TMG Technologie und Engineering GmbH

Copyright © 2019 TMG Technologie und Engineering GmbH

Technologie Management Gruppe
Technologie und Engineering

6

IO-Link Device Tool V5.1 – PE : Master Control

Port	Pin	Mode	Details	Vendor	Device
0	4	IO-Link		TMG TE GmbH	TMG Color 01
1	4	IO-Link		TMG TE GmbH	PureModule-01
2	4	IO-Link		J. Schnitzl GmbH	SCTM-IO_L_16
3	4	IO-Link		Cafe Garazza	CA18CAN128PM10
0	2	IO	DI		
1	2	IO	DI		
2	2	IO	DI		
3	2	IO	DI		

Port Config Details: Vendor ID: 0x014F, Device ID: 0x640003, Product ID: Color_01, Serial Number: I000, IO-Link Revision: V1.1, Inspection Level: COMPATIBLE.

Process Data: Configured Input Length: 32, Device Input Length: 13, Configured Output Length: 32, Device Output Length: 1, Data Storage Mode: ENABLED.

Copyright © 2019 TMG Technologie und Engineering GmbH

Technologie Management Gruppe
Technologie und Engineering

7

IO-Link Device Tool V5.1 – PE : IODD Interpreter

Name	R/W	Value	State	Unit
Standard Command	wo	White calibration		
Standard Command	wo	Teach Color 1		
Standard Command	wo	Teach Color 2		
Standard Command	wo	Teach Color 3		
Standard Command	wo	Teach Color 4		
Standard Command	wo	Teach Clear Limit		
Standard Command	wo	Teach IR Limit		
Standard Command	wo	Preset Temperature Values		
Standard Command	wo	Prestore Factory Settings		
[-] Options				
Gain	rw	1 x		
Integration Time	rw	25		
Nb of samples for moving average	rw	1		
Temperature Limit	rw	25.0		°C
Red Hysteresis	rw	10		%
Green Hysteresis	rw	10		%
Blue Hysteresis	rw	10		%
Pin2 Mode	rw	Ambient Light Switch		
[-] Teach values				
[-] White Calibration Values				
Red Correction	rw	100		%
Green Correction	rw	100		%
Blue Correction	rw	100		%
Clear Correction	rw	100		%
IR Correction	rw	100		%
[-] Teached Values Color 1				

Copyright © 2019 TMG Technologie und Engineering GmbH

Technologie Management Gruppe
Technologie und Engineering

8

IO-Link Device Tool V5.1 – PE – Open IO Device Graphical User Interface

Copyright © 2019 TMG Technologie und Engineering GmbH

Technologie Management Gruppe
Technologie und Engineering

9

Additional TAB Device GUI
if Device DLL is installed with IODD

TMG IO-Link Device Tool V5.1 with TMG USB – IO-Link Master V2

USB
INTEGRATED SERIAL BUS

IO-Link
Durchbruch in Sachen Kommunikation

- ▶ **Standard Edition (Service and Sales)**
 - Parameterization, observation and diagnosis of IO-Link devices
 - Free updates from Internet File Server
- ▶ **IO-Link Device Test System**
 - Functionality of Standard Edition +
 - Execution of certification test for IO-Link V1.1 and V1.0 devices
 - Test configuration from IODD
 - Performs all test cases for protocol test
 - Performs also timing tests
 - Creates test report for manufacturer declaration
 - Free updates from Internet File Server
- ▶ **USB IO-Link Master V2 – EMC**
 - EMC Test Master to perform IO-Link EMC Test
 - Check robustness of IO-Link communication
 - Easy to use

Copyright © 2019 TMG Technologie und Engineering GmbH

Technologie Management Gruppe
Technologie und Engineering

10

IO-Link Device Tool V3 – Test System

Copyright © 2019 TMG Technologie und Engineering GmbH

Technologie Management Gruppe
Technologie und Engineering

11

TEConcept Tools

Note: The following information is provided by TEConcept as an example of the types of products and services each software vendor provides. Please contact the software partner for further details.



enjoy technology...





IO-Link Test Centre



- For IO-Link Masters and Devices (wired)
 - Execution of protocol tests
 - Physical layer tests
 - EMC tests (in cooperation with ELMAC – EMC Lab.)
- Test reports suitable as attachment for **Manufacture Declaration of conformance** (also for non-IO-Link members)
- IO-Link related issue fixing support

IO-Link Competence Centre

- Support on IO-Link related subjects
- IO-Link related consulting
- IO-Link workshops (Software and Hardware design)
- IO-Link Development Support, Compatibility checking
- Software stacks for IO-Link Masters and Devices
- Supporting IO-Link Profiles
- Industrial interfaces (integration to ProfiNet, EtherCat, etc.)
- IO-Link Master Modules and Development Kits
- Complete IO-Link Product development, Hardware prototypes, software development support







enjoy technology...



IO-Link Master Stack

- Complies to the V1.1.2 IO-Link communication specification and ready for the V1.1.3 update.
- Multi-port support. The number of ports only limited by hardware resources.
- HW/SW Abstraction layers for easy porting.
- Fastest supported cycle times:
 - 0.4 ms @ 230.4 kBaud (COM3)
 - 2.3 ms @ 38.4 kBaud (COM2)
 - 18 ms @ 4.8 kBaud (COM1)
- System requirement: min 20MHz/port (for COM3).
- Software interface via shared parameters or by the Standardized Master Interface (SMI)
- Control and test API



Supported IO-Link ASICs:

- Maxim MAX14824, MAX14819
- (All common IO-Link PHYs with and without frame handler are supported)



Supported processors:

- STMicroelectronics STM32 series (Cortex M0, M3, M4, M7)
- Atmel ATSAM3S (Cortex M3)
- NXP LPC series (Cortex M0, M3, M4)
- NXP (Freescale) KL series (Cortex M0+)
- Texas Instruments Sitara AM4x (Cortex A9)
- Renesas RX23X, SH-2A (SuperH)
- Cypress S6E2H (Cortex M4F)



enjoy technology... **TEConcept**

High-Level IO-Link Master Access module

- Provides easy-to-use access to IO-Link Master Stack
- Compatible with the latest V1.1.3 IO-Link specification
- Uses the Standardized Master Interface (SMI) of the IO-Link Master stack
- Communicates with the IO-Link Master through ArgBlocks
- Real-time Process Data exchange between the user application and the IO-Link Master
- Can be used directly on the IO-Link Master chip or on separate platform with a help of an ArgBlock transport mechanism
- Easy-to-use API, written in ANSI C with focus on efficiency
- Small footprint:
 - 30-50 kB of RAM usage

Supported platforms / processors:

- Completely platform-independent
- Supports any kind of C compilers
- Runs on any kind of microcontrollers
- Runs on desktop PCs with Windows and Linux operating systems

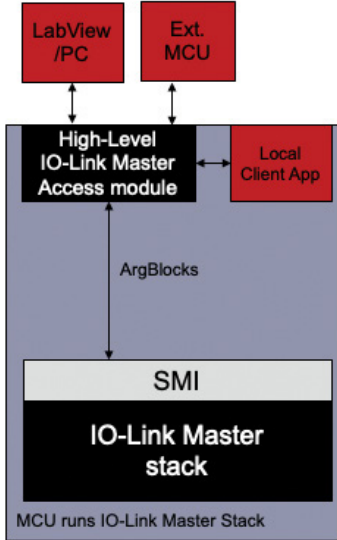



enjoy technology... **TEConcept**

Integration and mapping for IO-Link (Masters)

with JSON/REST API: {JSON}

- Compliant with the JSON integration for IO-Link standard specification.
- Diagnostics and parameterization over Web and cloud systems
- Provides a device data model, objects mapping for IO-Link system to IT
- Easy integration to any JSON clients (PDCT or HMI),
- IODD management and upload
- MQTT support
- Small memory footprint, ideal for embedded systems

Requirements:

- Requires V1.1.3 IO-Link Master stack (uses SMI), Ethernet connection, TCP/IP and HTTP server

With OPC UA: 

- Compliant with the OPC UA for IO-Link companion specification
- Generic model implementation
- Generic ISDU read/write, subscription to Device parameters and events.
- IO-Link Master stack on the same MCU possible
- Includes OPC UA embedded stack (ANSI C),
- Small footprint (~15kByte RAM per IO-Link port)
- TCP-Binary server access

Requirements:

- Requires V1.1.3 IO-Link Master stack (uses SMI), Ethernet connection, TCP/IP and BSD Sockets



enjoy technology... **TEConcept**

IO-Link Device Stack

- Compliant to IO-Link interface specification V1.1.2 and V1.1.3 supporting all described features
- Process data handling synchronous or asynchronous to IO-Link cycle
- System load ~50 % on 8-Bit processor @ 16 MHz
- Porting to different μ Cs and IO-Link PHYs requires only an exchange of drivers. HW/SW Abstraction layers for easy porting.
- Required μ C peripherals: UART, GPIO, 16-bit timer
- Parameter Manager for easy access to custom ISDUs
- Interface to non-volatile storage of Parameters
- Sample application supporting common profile

Supported IO-Link ASICs:

- MAXIM IO-Link PHYs (MAX 14821/14827A/14828/22513)
- (All common IO-Link PHYs with and without frame-handler are supported)



Supported processors:

- Maxim MAX32660
- STM32 (Cortex M0, Cortex M3, Cortex M4)
- STMicroelectronics STM8L/STM8S
- Renesas RL78
- Silicon Labs C8051F31x
- NXP LPC11xx (Cortex M0)
- Atmel ATSAM3S (Cortex M3)
- Atmel ATmega32/64/128
- MSP430
- Kinetis KL-series
- **Portable to almost any platform...**



enjoy technology... **TEConcept**

IO-Link Device Stack: Firmware Update Profile

- Complies to IOL-Profile-Firmware-Update V1.1 specification
- Can be added to an existing IO-Link Device
- Bootloader with integrated firmware decryption function, encryption is done on a PC with the „IOLFW“ file creator.
- Reference implementation for STM32 microcontroller, portable to other platforms
- Complete toolchain for firmware update:
 - IOLFW Package Creator including encryption
 - IO-Link Control-Tool supports firmware update and BLOB transfer
 - Bootloader firmware
 - Extended IO-Link Device stack with new System Commands

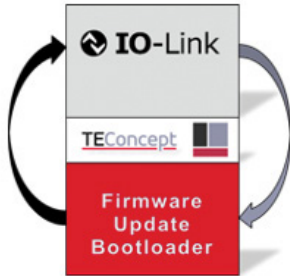



enjoy technology... **TEConcept**

IO-Link Control Tool (4.0)

- Rich and Customizable UI
(available for OEM/brand labeling)
- Multiple IO-Link Master Control (In Parallel)
- Easily Extendable (Plugins)
- Local IODD Catalog Handler, IODD Interpreter
- Remote IODD file download function, by the IODD Finder Integration
- IO-Link Port Configuration and Parametrization
- Supports any IO-Link Master which supports JSON integration
- Profile Support:
 - Device Firmware Download Support
 - BLOB Transfer Support
- Data Storage Content Exchange Support
- IO-Link Safety Support
- Role based Authorization





enjoy technology... **TEConcept**

IODD Designer

- Simplifies generation and development of IO-Link Device Descriptor (IODD) files.
- Runs on any Windows 7/8/10 PC.
- Simple „wizard-like“, step-by-step IODD generation
- Integration with the official IODD Checker is possible to verify and stamp the generated IODD.

Advantages:

- Supports V1.0 and V1.1 compliant IODD files and IO-Link Profiles
- No XML-Knowhow required
- Integrates the IODD Checkers
- Existing IODDs can be imported
- Working state can be saved and restored

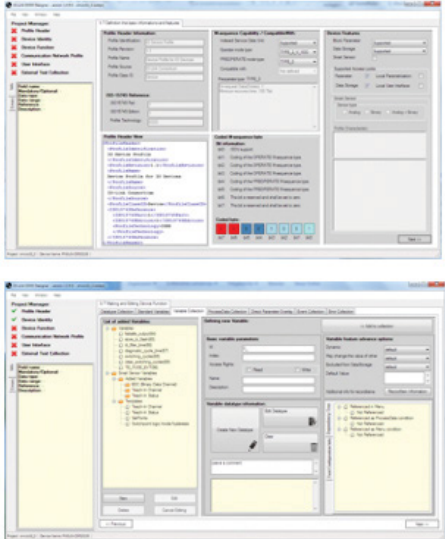



enjoy technology... **TEConcept**

IO-Link Diagnosis Tool

- Timing accurate IO-Link signal analysis
- Timing precise software UART decoding
- Optional hardware signal direction detection
- Byte-, frame-, protocol- or IODD-based decoding of IO-Link signal
- Sophisticated filtering and search features
- Configuration image based on transferred
- Recording to PC / SD-card
- Analog time signal view for UL+, IL+, UCQ, ICQ
- Eye diagram view separated for Device/Master
- Interactive rulers for analogue measurements
- Calibration of measured voltages and currents

Advantages:

- Fast and easy IO-Link issue analysis
- Logical and electrical issue detection
- Suitable for development and application





enjoy technology... **TEConcept**

IO-Link Physical Layer Tester

- Compliant to IO-Link Test Specification V1.1.2 (V1.1.3 coming)
- User calibration support
- IODD support
- Integrated IO-Link Master
- Integrated Line Simulation
- Semiautomatic measurement procedure based on recorded waveforms
- SIO – Mode tests
- BIT – and UART Eye-Diagrams
- Test Report Generation (PDF)
- All test results are stored in a reloadable test data file

Advantages:

- All components to run physical Layer Tests are included
- Substantial reduction of test effort and test duration
- Automatic test report generation

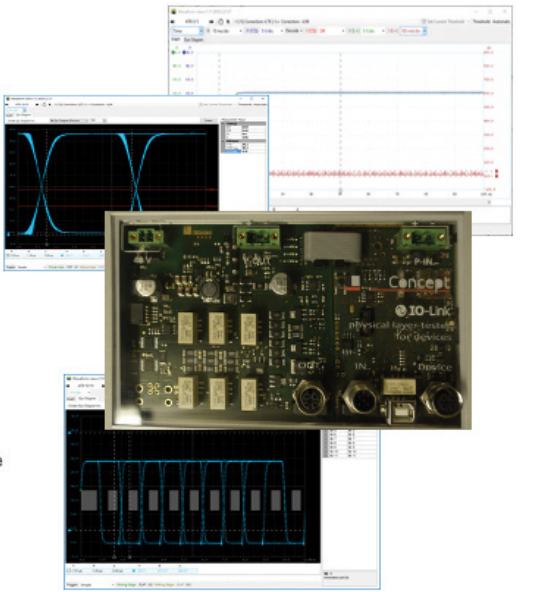





enjoy technology... **TEConcept**

IO-Link EMC Test Master

- Complies to IO-Link interface specification V1.1.2 (V1.1.3 coming) and the current IO-Link test specification.
- Error and Signal output
- 4 electrical IO-Link port configurations
 - COM1/2 speed port (good/bad signal)
 - COM3 speed port (good/bad signal)
- RS232 and USB interfaces
- Terminal based control command set
- Additional EMC test and control software with graphical user interface
- Test report generation in PDF Format
- Operates as standard "USB IO-Link Master,"

Advantages:

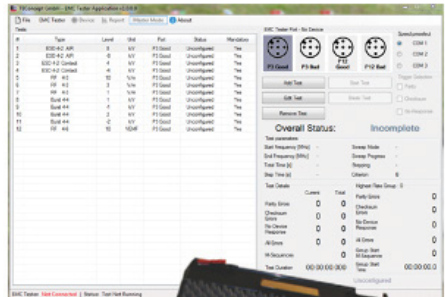
- Sensitive Parts are located outside EMC chamber
- EMC robustness considerably better than required



enjoy technology... **TEConcept**

IO-Link EMC Test Device

- Device fully compliant to V1.1.2 IO-Link Interface Specification
- All 3 COM-Speeds supported (Switch Selector)
- Internal Pseudo-Random-Number Generators
- Error counter for Parity, Checksum, Data and Time-out Errors
- 7-Segment Error Counter Display
- 7-Segment Device Status Display
- Errors Counter accessible via IO-Link
- Optical Error Trigger Output

Advantages:

- No development effort for master manufacturers
- Better time-to-market
- Identification of EMC issues





enjoy technology... **TEConcept**

IO-Link Device Tester System

- Test cases are defined in the IO-Link test specification
- TEConcept Device tester simplifies the execution protocol compliance tests.
- Generates **Manufacturer Declaration/Test report (PDF)**

Advantages:

- Complies to IO-Link Test specification V1.1.2 (V1.1.3 support in preparation)
- IO-Link profiles (FW-Update, BLOB Transfer, etc. are supported)
- Extendible with customer specific test cases
- Selectable Test Case execution
- Hex-Trace of IO-Link communication
- Log- and Trace File export
- Session store/restore (project file)





enjoy technology... **TEConcept**

IO-Link Tools – Master Tester - Overview

- All baud rates supported
- Upgradeable for new IO-Link features
- Alternative adaption to for fieldbus interfaces via DLLs.

Advantages:

- Support for new serial Test Interface
- Generic serial DLL
- Windows 7/10 compliant (64bit)
- V1.2 Test-spec compliant (V1.1.3 coming soon)

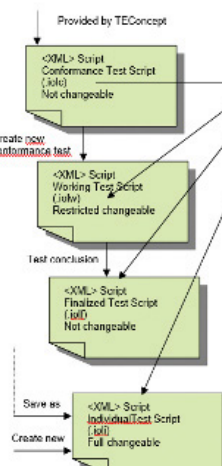
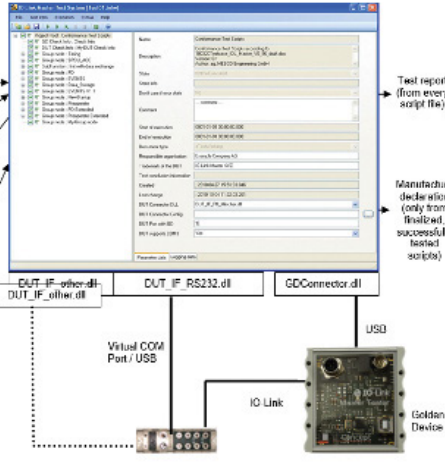
IQ² Development Tools

Note: The following information is provided by IQ² as an example of the types of products and services it provides. Please contact them for further details.

IQ² Development

Complete Hardware and Software example for DEVICE STACK integration

To simplify IQ² Device stack integration into Customers device, a complete example (hardware and software) is available:

1. Hardware

- Hardware is based on "MAXIM IO-LINK TEMPERATURE SENSOR (MAXREFDES173)" Device. See more: www.maximintegrated.com



- IO-Link device transceiver: **MAX14827A** (Low-Power, Ultra-Small, Dual Driver, IO-Link Device Transceiver)
 - Sensor: **MAX31875** (Low-Power I2C Temperature Sensor)
 - Main microcontroller: **Renesas RL78/G1A**
- ### 2. Software
- IO-Link Device stack: **IQ2 Development**, <https://www.iq2-development.com/products/isstacks.html>
 - IO-Link Device application: **IQ2 Development**.

The MAXREFDES173 is an IO-Link® temperature sensor reference design uses a ±2°C-accurate local temperature sensor with I2C/SMBus interface (MAX31875) and Low-Power, Ultra-Small, Dual Driver, IO-Link Device Transceiver (MAX14827A). The sensor uses IQ2 Development's IO-Link device stack to communicate to any IO-Link version 1.1-compliant master (for example: iqLink (<https://www.iq2-development.com/products/iqlink.html>)). The board also contains a male M12 connector for connection to a compliant IO-Link master using a standard M12 cable.

www.iq2-development.com

IQ² Development

Complete Hardware and Software example for DEVICE STACK integration

To simplify IQ² Device stack integration into Customers device, a complete example (hardware and software) is available:

1. Hardware

- Hardware is based on "MAXIM IO-LINK LASER DISTANCE SENSOR (MAXREFDES174)" Device. See more: www.maximintegrated.com



- IO-Link device transceiver: **MAX22513** (Surge Protected Dual Driver IO-Link Device Transceiver with DC-DC)
 - Sensor: **VL53L1X** (long distance ranging Time-of-Flight sensor)
 - Main microcontroller: **Renesas RL78/G1A**
- ### 2. Software
- IO-Link Device stack: **IQ2 Development**, <https://www.iq2-development.com/products/isstacks.html>
 - IO-Link Device application: **IQ2 Development**.

The MAXREFDES174 is an IO-Link® distance sensor reference design uses a long distance ranging Time-of-Flight sensor (VL53L1X) and Surge Protected Dual Driver IO-Link Device Transceiver with DC-DC (MAX22513). The sensor uses IQ2 Development's IO-Link device stack to communicate to any IO-Link version 1.1-compliant master (for example: iqLink (<https://www.iq2-development.com/products/iqlink.html>)). The board also contains a male M12 connector for connection to a compliant IO-Link master using a standard M12 cable.

www.iq2-development.com

DATA SHEET iqLink USB IO-LINK MASTER IQ² Development

1: mini USB
2: LED operating condition/ error message
3: 24 V DC 05,5/2,1mm
4: M12x1 Type A female

CE IO-Link

Product features	
USB IO-Link Master	
Parameterize devices and monitoring of process data	
Supported communication protocols: IO-Link, COM 1 (4.8 kBit/s) / COM 2 (38.4 kBit/s) / COM 3 (230 kBit/s)	
For operation with iqPDCT (Port and Device Configuration Tool)	
Electrical data	
Output voltage in USB mode, V	24 V DC ± 10%
Output voltage with external power supply, V	24 V DC ± 6V (max. input voltage)
Output current in USB mode, mA	80 mA
Output current with external power supply, A	max. input current <2,5 A
Input voltage on USB mode, V	5 V DC
Input voltage with external power supply, V	24 V DC ± 6V (according to DIN EN60950)
Input current in USB mode, mA	max. 600 mA
Input current with external power supply, A	max. 2,5 A
Outputs	
Short-circuit protection	yes
Interfaces	
IO-Link-Master transmission type	COM 1 / COM 2 / COM 3
IO-Link revision	V1.0 and V1.1
Number of ports	1
Port class	M12x1 / Type A / female
Environmental conditions	
Ambient temperature, °C	0 to +55 °C
IP protection class	IP 20

IQ² Development GmbH & Co. KG, Carl-Benz-Str. 3, 72585 Riederich
www.iq2-development.de, info@iq2-development.de

DATA SHEET iqLink USB IO-LINK MASTER IQ² Development

Registrations / Checks	
EMV Guideline 2014/30/EU	DIN EN 61000-6-2:2005 DIN EN 61000-6-4:2007+A1:2011 DIN EN 61131-9:2013
RoHS Guideline 2011/65/EU	fulfilled
Mechanical data	
Weight, kg	0,066 kg (net) / 0,106 kg (gross)
Material	Aluminium anodized
Display / Diagnose	
Display	Operation condition: LED green light permanently on = iqLink ready, no IO-Link Communication LED green light, active IO-Link communication flashes at 900 msec and 100 msec off = iqLink ready error indication: LED red light permanently on (LED green light cut) = please send iqLink to the manufacturer
Diagnose	
Electrical connection	
Connection Assignment:	
1: +24 V 2: not occupied 3: GND 4: IO-LINK: CH1 (C/Q) 5: not occupied	
1: +5 V 2: D- 3: D+ 4: not occupied 5: GND	
Remarks	
IO-Link Master Transceiver:	Maxim MAX14819ATM+
Main Microcontroller	Renesas RL78/G13 (R5F100)
Packaging unit, pieces	1 Piece
Country of origin	DE
HS-Code	85437090

Recycling remarks
This product is to be supplied after his use according to the topical disposal regulations of your administrative district, country and state as an electronic industry waste of a separate disposal.

The information contained in this data sheet was compiled with the greatest possible care. For correctness, completeness and actuality the liability is limited to coarse fault.

VERSION v.1.1 (0808 0919)

IQ² Development GmbH & Co. KG, Carl-Benz-Str. 3, 72585 Riederich
www.iq2-development.de, info@iq2-development.de

Company Profile



This system is developed by Hefei Onsoon Intelligent Electronic Co., Ltd. Onsoon is a national Hi-tech enterprise located in Hefei, Anhui Province.

The company's main business includes: IO-Link tool development, IO-Link solution development, and sensor chip design. Products include 4-port IO-Link USB master, single-port IO-Link master, PDCT software, IODD generation, and utilization integrated system.

Hefei Onsoon Intelligent Electronics Co., Ltd.
4th floor, No. 3 Factory Building, Yingtang Science and Technology Park, No. 99, Fushan Road, Shushan District, Hefei City

Phone: 0551-65261850
Contact: Cong Liu
Email: liucong@onsoon.cn

IO-Link Glossary

(Reprinted with permission from io-link.com.)

Acyclic Data	Data transmitted from the controller only after a request (for example, parameter data, diagnostic data).
COM1-3	IO-Link data transmission rates.
Cyclic Data	Data that is transmitted by the controller automatically and at regular intervals (process data, value status).
DI	Digital input.
DO	Digital output.
GSD File	The properties of a PROFINET device are described in a GSD file (generic Station Description), which contains all information required for configuring.
HMI	Human machine interface of an automatic system.
IEC 61131-9	International standard that deals with the basics of programmable controllers. Part 9 describes IO-Link under the designation single-drop digital communication interface for small sensors and actuators (SDCI).
IODD	Electronic device description of devices (IO device description).
IO-Link device	Field device that is monitored and controlled by an IO-Link master.
IO-Link Master	Represents the connection between a higher-level fieldbus and the IO-Link devices. The IO-Link master monitors and controls the IO-Link devices.
Parameter Assignment Server	An IO-Link master according to IO-Link Specification 1.1 can act as a parameter assignment server for the IO-Link device.
Port	A port is an IO-Link communication channel.

IO-Link FAQs

Q: What components are recommended for protection during burst events?

A: We generally recommend that customers place pads for two capacitors (~220 pF) on the C/Q line (one to GND and one to V_{CC}) for burst testing (IEC 61000-4-4). These capacitors should be placed as close to the IC as possible. Depending on the board, these capacitors may not be needed to pass burst testing, so we recommend testing without the capacitors first and then adding them, if needed.

TVS diodes with a clamp voltage lower than the absolute maximum ratings for the transceiver are required for protection during a surge event. Place TVS diodes as close to the IC as possible.

Q: Some IO-Link designs appear to have isolated ground planes. What is the isolation for?

A: While there is no requirement for isolation in the IO-Link specification, all IO-Link systems have isolation at some point in the signal chain. Isolation ensures that the controller/backplane is protected from any transient events that occur on the local 24 V field supply. The isolation is usually placed in a location where the cost is minimized, for example, between the backplane and the controller or between the controller and the IO-Link transceiver.

Q: What is SIO and how does it relate to IO-Link?

A: Per the IO-Link specification, every IO-Link master port can be configured to operate in SIO (single input/output) mode or IO-Link (SDCI) communication mode. In SIO mode, the port can be configured to operate as a digital input or a digital output. See IEC 61121-2 for more information.

Q: Some IO-Link master transceivers have a DI input and some do not. What is DI?

A: DI is a digital input. Digital inputs are the most common inputs in industrial systems. DI is used to connect to binary sensors.

Q: Why does IO-Link support three different data rates?

A: Many industrial systems have existed for many years. While data rates in communication systems have increased significantly, many of those original sensors (often still operating in their original systems) were designed with slower software/communication capabilities. The IO-Link specification incorporates communication at three data rates that include most sensor capabilities to allow upgrades and improvements to industrial systems already in place, without requiring complete (and very expensive) overhauls.

Q: Do IO-Link masters and devices have to be surge protected?

A: Since IO-Link cables are specified for a maximum length of 20 m, and the IEC 61000-4-5 surge standard mandates surge for cables longer than 30 m, the IO-Link standard does not require surge protection.

Q: What is the maximum input capacitance pin that an IO-Link master may have on the C/Q pin?

A: An IO-Link master's input capacitance must be ≤ 1 nF in receive mode in the frequency range up to 4 MHz.

Q: What is the maximum capacitance that an IO-Link device may have?

A: The IO-Link device input capacitance should be ≤ 1 nF. An exception is made in cases of COM1 or COM2 data rates in combination with push-pull driver operation, in which case, the maximum input capacitance may be up to 10 nF.

Q: What is an IO-Link cable?

A: An IO-Link cable has at least 3 wires (C/Q, L+, and L-). The cable is not shielded.

Q: What is the maximum length of IO-Link cable?

A: The maximum cable length is 20 m.

Q: What is the cable's worst-case resistance and capacitance allowed to be?

A: The loop wire resistance is 6.0 Ω (max) while the maximum cable capacitance (C/Q to L+/L-) is 3.0 nF (to 1 MHz).

Q: Is the IO-Link cable terminated?

A: There is no specification for the termination of IO-Link cables. Hence, the voltage waveform on an IO-Link cable can exhibit overshoots.

Q: What is meant by IO-Link cycle time?

A: The IO-Link cycle time is the repetition rate at which the IO-Link master sends out its master message to the IO-Link device in Operate mode. This is the rate at which the device is provided with or requested for process data; that is, the rate at which a sensor is asked for its measurement data or an actuator is given new data.

Q: What is the minimum IO-Link cycle time possible by the IO-Link standard?

A: The minimum cycle time is 400 μ s. Such small cycle times are only feasible with COM3 data rates.

Q: Can every IO-Link master support 400 μ s cycle times?

A: The IO-Link standard does not require that an IO-Link master support the 400 μ s minimum cycle time. Every IO-Link master specifies its own minimum cycle time capability.

Q: What is IO-Link communication based on?

A: IO-Link is based on a master-device dialogue in which the IO-Link master polls the IO-Link device, which must answer the master message.

Q: How fast must an IO-Link device respond to an IO-Link master message?

A: An IO-Link device must send out its first bit within 10 bit times after the last bit of the master message. Hence, the response time depends on the data rate (COM rate).

Q: What topology does IO-Link employ?

A: IO-Link is a point-to-point connection in which an IO-Link master is connected to only one IO-Link device.

Q: What is the current drive capability of an IO-Link master C/Q port?

A: The C/Q pin of an IO-Link master can drive at least 100 mA (min) continuously and 500 mA (min) for a short time (for the IO-Link wake-up).

Q: What is the supply voltage range that an IO-Link master must provide for powering IO-Link devices?

A: An IO-Link master must provide a 24 V power supply with a tolerance range of 20 V (min) to 30 V (max) to power IO-Link devices.

Q: At what load current must an IO-Link master be able to provide to an IO-Link device?

A: The IO-Link master must supply 200 mA continuously.

Q: What is the supply range of an IO-Link device?

A: An IO-Link device must operate with a 24 V nominal supply with a voltage range of 18 V (min) and 30 V (max).

Q: How much load current can an IO-Link device drive?

A: An IO-Link device is specified to drive at least 50 mA. It is common for IO-Link devices to drive at least 100 mA.

Q: Why are some IO-Link device transceivers able to drive 200 mA or more load current?

A: While such high currents are not needed for IO-Link operation, they may be needed if an IO-Link device (such as a switching sensor) is specified to drive large loads, as in valves or relays, in standard binary output mode.

Q: Can an IO-Link device driver operate in PNP or NPN mode during IO-Link communication?

A: IO-Link communication supports both push-pull and PNP modes. Push-pull is preferred, since the two logic states, defined when the device drives the C/Q line, are then defined by a low impedance driver. PNP mode is possible for the lower COM rates, in which case, the C/Q low is defined by the 5 mA pulldown in the IO-Link master.

Q: Can an IO-Link device operate in NPN mode?

A: An IO-Link device can only operate in NPN driver mode during SIO operation, if the IO-Link master supports NPN sensors. The IO-Link standard does not support NPN driver operation.

Q: I want to make my new IO-Link sensor compatible with older binary switching sensors that have PNP drivers. Can I operate the sensor in PNP mode?

A: When the sensor is operating in SIO mode, it can be operated in PNP mode so that it is compatible to the older sensors. When the sensor gets an IO-Link wake-up from the IO-Link master, it is suggested to switch its driver to push-pull mode.

Additional IO-Link Resources

IO-Link Webpages

[IO-Link Transceivers and Binary Drivers](#)

[IO-Link Master Transceivers](#)

[IO-Link Device Transceivers](#)

[Binary Drivers](#)

[IO-Link Reference Designs](#)

IO-Link Application Notes and Articles

[Application Note 6427: Calculating the Power Dissipation of the MAX14819A Dual-Channel IO-Link Master Transceiver](#)

[Application Note 5151: Special Considerations for Mode Changes During Active Operation of MAX14820/MAX14821 Sensor/Actuator Transceivers](#)

[Application Note 6965: How to Select a TVS Diode for IO-Link Devices](#)

[Looking Beyond IO-Link](#)

Videos

[Intelligence at the Edge with Configurable IO-Link Solutions](#)

[Intelligent Sensors for Industrial Automation](#)

[What Is IO-Link?](#)

[Learn the Fundamentals of IO-Link Technology](#)

[Heat Map Comparison of IO-Link Device Transceivers](#)

[In the Lab: IO-Link Smart Sensor System Demo](#)

Trademarks

Arm is a registered trademark and registered service mark, Cortex is a registered trademark, and Mbed is a trademark of Arm Limited.

IO-Link is a registered trademark of Profibus User Organization (PNO).

Renesas is a registered trademark and registered service mark of Renesas Electronics Corporation.

Windows is a registered trademark and registered service mark of Microsoft Corporation.