

# Product Document

A wireframe illustration of a car, showing the chassis, wheels, and body panels, rendered in a light blue color against a dark blue background.

# High-Speed, High-Resolution Rotary Position Sensor

[www.ams.com/AS5147P](http://www.ams.com/AS5147P)

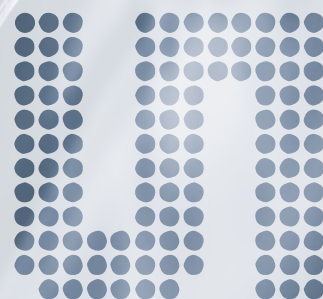

## **AS5147P – Safety-critical automotive applications**

- DAEC™ Dynamic Angle Error Compensation
- AEC-Q100 automotive qualified
- 14-bit core resolution, 12-bit binary incremental pulse count
- Immune to external stray-magnetic fields
- Highest accuracy
- Developed as Safety Element out-of-context (SEooC) according ISO26262

**We provide innovative analog solutions to the most challenging applications in sensor and sensor interfaces, power management, and wireless.**

## General Description

The AS5147P is a high-resolution rotary position sensor for high-speed (up to 28krpm) angle measurement over a full 360 degree range. This new position sensor is equipped with a revolutionary integrated dynamic angle error compensation (DAEC™) with almost 0 latency. The robust design of the device suppresses the influence of any homogenous external stray magnetic field. A standard 4-wire SPI serial interface allows a host micro-controller to read 14-bit absolute angle position data from the AS5147P and to program non-volatile settings without a dedicated programmer. Incremental movements are indicated on a set of ABI signals with a maximum resolution of 4096 steps / 1024 pulses per revolution. The resolution of ABI signal is programmable to 4096 steps / 1024 pulses

per revolution, 2048steps / 512 pulses per revolution or 1024 steps / 256 pulses per revolution. Brushless DC (BLDC) motors are controlled through a standard UVW commutation interface with a programmable number of pole pairs from 1 to 7. The absolute angle position is also provided as PWM-encoded output signal. The AS5147P supports embedded self-diagnostics including magnetic field strength too high, magnetic field strength too low or lost magnet, and other related diagnostic features. The product is defined as SEooC according ISO26262 including FMEDA, safety manual and third-party qualification.

### Benefits

- Eliminates angle measurement lag at high RPMs
- Lower system costs (no shielding)
- High resolution for motor and position control
- Simple replacement – reduces system cost
- Fast high-resolution position feedback
- Provides absolute and incremental angle measurements
- No programmer needed (via SPI command)
- Enables ASIL-x system safety level compliance

### Features

- DAEC™ Dynamic angle error compensation
- Immune to external stray-magnetic fields
- 14-bit core resolution
- Encoder output: 1024 pulses
- Maximum speed up to 28.000 rpm
- SPI, PWM, UVW and ABI Interfaces
- Zero position, configuration programmable
- Developed per ISO 26262 SEooC

### Applications

- Safety Critical Automotive Systems
  - EPS, Brakes and Airbags, for example
- Resolver replacement
- Discrete Hall commutation feedback replacement
- Servo motor position control
- BLDC/PMSM motor commutation
  - Pumps, DCT, Starter, Alternator, and Wipers, for example

### DAEC™ Latency Comparison



### AS5147P Block Diagram

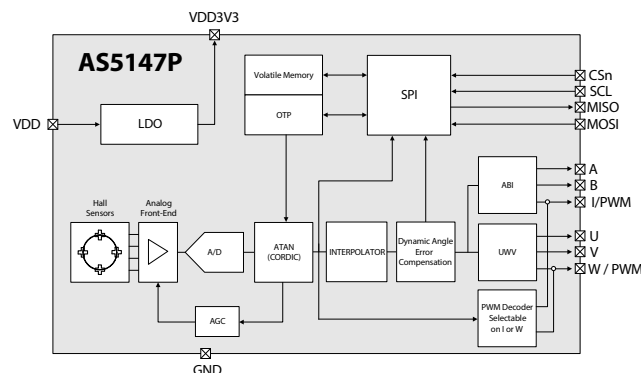

www.ams.com  
 products@ams.com  
 © 05/2015 by ams  
 Subject to change without notice

**Headquarters**  
**ams AG**  
 Tobelbader Strasse 30, 8141 Unterpemstaetten, Austria  
 Phone +43 3136 500-0 • Fax +43 3136 525-01



**Sales Offices Worldwide**  
 sales-europe@ams.com  
 sales-asia@ams.com  
 sales-americas@ams.com