

Precision, Unipolar, Noninverting Configuration for the **AD5547/AD5557** DAC

CIRCUIT FUNCTION AND BENEFITS

The circuit shown in Figure 1 provides precision, unipolar, noninverting data conversion using the **AD5547/AD5557** current output digital-to-analog converter (DAC) with the **ADR03** precision reference and **AD8628** operational amplifier (op amp). This circuit provides accurate, low noise, high speed output voltage capability and is well suited for process control, automatic test equipment, and digital calibration applications.

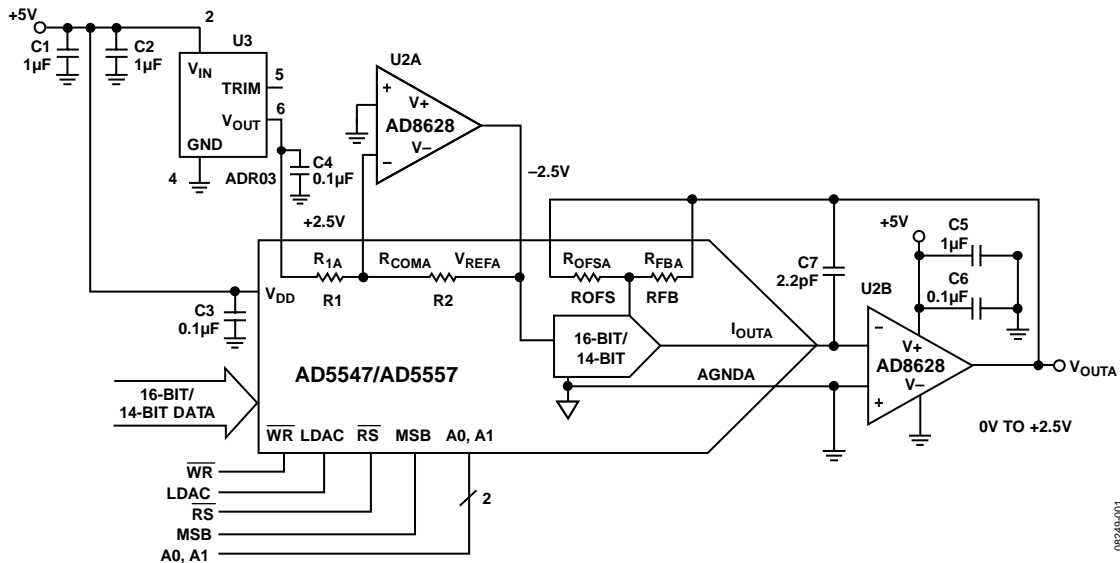

Figure 1. Unipolar 2-Quadrant Multiplying Mode, $V_{OUT} = 0\text{ V to }+V_{REF}$ (Simplified Schematic)

08249-001

TABLE OF CONTENTS

| | | | |
|------------------------------------|---|------------------------|---|
| Circuit Function and Benefits..... | 1 | Common Variations..... | 3 |
| Revision History | 2 | References..... | 3 |
| Circuit Description..... | 3 | | |

REVISION HISTORY

11/2017—Rev. A to Rev. B

| | |
|---|-----------|
| Document Title Changed from CN0027 to AN-1490 | Universal |
| Changes to Figure 1 | 1 |

5/2009—Rev. 0 to Rev. A

| | |
|--|-----------|
| Updated Format..... | Universal |
| Changes to Figure 1 | 1 |
| Changes to Circuit Description Section | 3 |

10/2008—Revision 0: Initial Version

CIRCUIT DESCRIPTION

The [AD5547/AD5557](#) are dual-channel, precision, 16-bit/14-bit, multiplying, low power, current output, parallel input DACs. They operate from a single 2.7 V to 5.5 V supply with ± 15 V multiplying references for 4-quadrant outputs. Built in 4-quadrant resistors facilitate the resistance matching and temperature tracking that minimize the number of components needed for multiquadrant applications.

This circuit uses the [ADR03](#), which is a high accuracy, high stability, 2.5 V precision voltage reference. Temperature coefficient and long-term drift are primary considerations for applications that require high precision conversion; therefore, the [ADR03](#) is an ideal candidate.

An op amp is used in the current to voltage (I to V) stage of this circuit. The bias current and offset voltage of an op amp are important selection criteria for use with precision current output DACs. This circuit uses the [AD8628](#) auto-zero op amp, with ultralow input offset voltage (1 μ V typical) and input bias current (30 pA typical). C7 is a compensation capacitor. The value of C7 for this application is 2.2 pF, which is optimized to compensate for the external output capacitance of the DAC.

Note that the [AD8628](#) has rail-to-rail input and output stages; however, the output can only come within a few millivolts of either rail depending on the load current. For the circuit shown in Figure 1, the output can swing from approximately 1 mV to 2.5 V.

The input offset voltage of the op amp is multiplied by the variable noise gain (due to the code dependent output resistance of the DAC) of the circuit. A change in this noise gain between two adjacent digital codes produces a step change in the output voltage due to the input offset voltage of the amplifier. This output voltage change is superimposed on the desired change in output between the two codes and produces a differential linearity error, which, if large enough, can cause the DAC to be nonmonotonic. Generally, the input offset voltage should be a fraction of an LSB to ensure monotonic behavior when stepping through codes. For the [ADR03](#) and the [AD5547](#), the LSB size is

$$2.5 \text{ V}/2^{16} = 38 \mu\text{V} \quad (1)$$

The input offset voltage of the [AD8628](#) auto-zero op amp is typically 1 μ V, which is negligible compared to the LSB size.

The input bias current of an op amp also generates an offset at the voltage output as a result of the bias current flowing through the feedback resistor, RFB. In the case of the [AD8628](#), the input bias current is only 30 pA typical, which, when flowing through the RFB resistor (10 k Ω typical) produces an error of only 0.3 μ V.

The [AD5547/AD5557](#) DAC architecture uses a current steering rail-to-rail ladder design that requires an external reference and op amp to convert to an output voltage.

Use the following equation to calculate V_{OUT} for the [AD5547](#):

$$V_{OUT} = \frac{+V_{REF} \times D}{2^{16}} \quad (2)$$

where D is the decimal equivalent of the input code.

Use the following equation to calculate V_{OUT} for the [AD5557](#):

$$V_{OUT} = \frac{+V_{REF} \times D}{2^{14}} \quad (3)$$

COMMON VARIATIONS

The [AD8629](#) is a dual version of the [AD8628](#). The [AD8605](#) is another excellent op amp candidate for the I to V conversion circuit. It also has a low input offset voltage and low input bias current. The [ADR01](#) and [ADR02](#) are other low noise references available from the same reference family as the [ADR03](#). Other suitable low noise references are the [ADR441](#) and [ADR445](#). The size of the reference input voltage is restricted by the rail-to-rail voltage of the op amp selected.

These circuits can also be used as a variable gain element by utilizing the multiplying bandwidth nature of the rail-to-rail structure of the [AD5547/AD5557](#) DAC. In this configuration, remove the external precision reference and apply the signal to be multiplied to the reference input pins of the DAC.

REFERENCES

[ADIsimPower Design Tool](#).

Kester, Walt. 2005. Chapter 3 and Chapter 7, *The Data Conversion Handbook*. Analog Devices.

MT-015 Tutorial, *Basic DAC Architectures II: Binary DACs*. Analog Devices.

MT-031 Tutorial, *Grounding Data Converters and Solving the Mystery of AGND and DGND*. Analog Devices.

MT-033 Tutorial, *Voltage Feedback Op Amp Gain and Bandwidth*. Analog Devices.

MT-035 Tutorial, *Op Amp Inputs, Outputs, Single-Supply, and Rail-to-Rail Issues*. Analog Devices.

MT-055 Tutorial, *Chopper Stabilized (Auto-Zero) Precision Op Amps*. Analog Devices.

MT-101 Tutorial, *Decoupling Techniques*. Analog Devices.